

Feature Geometry and Head-Splitting in the Wolof clausal periphery

Martina Martinović

1 Introduction

This paper¹ is a study of the morphosyntax of the clausal periphery in the Niger-Congo language Wolof, specifically the two layers commonly labeled CP and TP/InflP. I investigate how these layers are related, and how their relationship should best be modeled. Two issues are at the core of this work: the connection between the heads traditionally called C and T/Infl, and the distribution of syntactic features across heads in the functional spine.

It has long been noted that the head that hosts the complementizer and the head that hosts the subject (and often features such as tense and agreement) share a number of properties. Strong evidence comes from languages (e.g. Irish, some Bantu languages, such as Kinande and Lubukusu) in which C exhibits features traditionally associated with verbal inflection, such as φ -features and tense. Even in English, the link between C and T is obvious: finite and infinitival Ts are selected by different complementizers, and the lack of a finite C results in the lack of φ -features on T and its inability to license a nominative subject. All this has led to various formal implementations of the relationship between C and T, most recently in the form of a theory of *Feature Inheritance*, according to which all formal features are generated on phase heads and appear on lower heads only by being passed down (Chomsky 2005, 2008; Richards 2007, 2011). It was, however, quickly noted that the prediction that all features (aside from the Edge feature, which triggers movement to Spec,CP) are passed down is too strong, and that often some T-like features are found on C, appear on both C and T/Infl, or are bundled together on one head (e.g. Fortuny 2008; Ouali 2008; Legate 2011; Gallego 2014, 2017; Erlewine 2018).

It is also a long-standing observation that languages differ in the amount of structure over which functional features are distributed. For example, tense, mood, and agreement can be expressed on multiple heads in some languages, and contained on one head in others (e.g. Giorgi and Pianesi 1996; Bobaljik and Thráinsson 1998), as can features found on Voice and v (Pylkkänen 2002, 2008; Harley 2017), and elsewhere. I call the structure in which features are spread out over multiple heads *cartographic*, referencing the work within the Cartographic project, aimed at creating a detailed inventory and hierarchy of functional categories (a.o. Rizzi 1997, 2002, 2004; Cinque 1999, 2006), and the structure in which features are bundled on fewer heads *non-cartographic*.

¹This paper is an elaboration and expansion of the work in Martinović 2015a, 2017a.

This cross-linguistic variation is usually captured via parametrization, however, this cannot easily account for cartographic and non-cartographic effects within one language.

I here propose a structure-building mechanism which can explain both the C-T relationship, and the variation in the distribution of features over syntactic heads. I argue, as in the Feature Inheritance theory, that features of C and T are bundled together, and that this feature bundle can be divided into multiple heads via a mechanism I call *Head-Splitting*, which allows parts of feature bundles to reproject and create new heads. The proposal is illustrated through a detailed exploration of the C-Infl domain in Wolof, which turns out to be highly relevant for the advancement of our understanding of the link between syntactic positions at the clausal periphery and the distribution of features that inhabit them.

Wolof clauses contain overt *sentence particles* – complementizer-like elements whose presence is obligatory in order for the clause to contain tense/aspect markers (Njie 1982) or negation (Zribi-Hertz and Diagne 2003), which directly points to a link between C and the heads in the inflectional layer. Works in both the descriptive and the generative tradition identify up to a dozen of these elements (Mangold 1977; Church 1981; Dialo 1981; Njie 1982; Robert 1991; Dunigan 1994; Zribi-Hertz and Diagne 2002; Torrence 2005, 2012), however, a careful inspection of their morphosyntax reveals that all particles occurring in finite clauses can be divided into two groups: those in which a verb is located in the same head as the particle, which I term *V-raising clauses*, and those in which an A'-moved XP occupies its specifier, the *Wh-raising clauses*. The morphosyntactic properties of the two clause-types point to a novel way of viewing the relationship between the heads at the clausal periphery. They are exemplified in (1) and (2), with sentence particles in bold face.

- | | |
|---|---|
| <p>(1) <u>V-raising: Neutral clause</u>²
 (Xale yi) lekk-na=ñu gato.
 child the.PL eat-C_V=3PL cake
 “The children ate cake.”</p> | <p>(2) <u>Wh-raising: Wh-question</u>
 Lan la {=ñu/xale yi} lekk?
 what C_{Wh} 3PL/child the.PL ate
 “What did {they/the children} eat?”</p> |
|---|---|

There are three syntactic differences between V-raising and Wh-raising clauses. In (1), the verb is located to the left of the particle *na*. The optional non-clitic subject is also to the left of the particle (and to the left of the verb). And finally, there is an obligatory subject clitic right-adjacent to *na* (*ñu*). In (2) the verb is below the sentence particle *la*, with the *wh*-phrase (here the object) to its left. Crucially, in this clause-type, the non-clitic and the clitic subject are in complementary distribution to the right of C, and neither is optional.

V-raising clauses do not appear to have an overt CP-layer, in fact, based on (1), we may be tempted to classify Wolof as a null-subject language with subject-verb agreement. Familiarizing ourselves with the morphosyntax of sentence particles, however, forces us to classify *na* as one, meaning that we also must allow for the verb to have moved to the same position. What, then, is the status of the lexical subject, and of the element encoding its φ -features, *ñu*? The Wh-raising clause in (2) presents a different picture. The lexical subject and *ñu*, which we might identify as agreement in V-raising clauses, are in complementary distribution in what appears to be the traditional subject position below C.

The main argument in this paper is that the superficial description of the two clause-types I just presented is very much on the right track. V-raising clauses have one high functional projec-

²Abbreviations used in this article: CM = class marker, INF = infinitive, IPFV = imperfective, LOC = locative clitic, OBJ = object clitic, PL = plural, PST = past tense, SG = singular, STR.PRON = strong pronoun.

tion, whose head combines the features of both C and the head typically hosting the subject in its specifier. In Martinović 2019 I argue extensively that Tense is a lower head in Wolof, below the head that hosts the subject, which I here label Infl, and below negation, when it is present.³ Since C and Infl are not separate projections in V-raising clauses, there is no position where the subject could get nominative case, which in Wolof is assigned under immediate c-command by C. Wolof, however, has C-oriented clitics, which can get into a position where they are assigned case. Therefore the only type of clause-internal subject allowed (and obligatory) in V-raising clauses is a pronominal one.

Wh-raising clauses have separate C and Infl projections: there is a higher head with an overt complementizer and a *wh*-moved nominal in its specifier, and a lower one, with a place for the subject, which is now in a position where it can get nominative case. Wh-raising clauses can therefore have a non-clitic subject below C. I derive the difference between V-raising and Wh-raising clauses by assuming that C and Infl in fact start out as a single head, which either stays unified, or splits, depending on purely syntactic circumstances. The main contribution of this paper is the detailed development of the mechanism of *Head-Splitting*, which distributes the features between the two heads.

The paper proceeds as follows. In section 2 I discuss the syntax of sentence particles, subject clitics, and non-clitic subjects, and the core data to be analyzed in the remainder of the paper. Section 3 presents the mechanism of *Head-Splitting*. Sections 4 and 5 apply the analysis to two Wolof clause-types. Finally, section 6 presents data from clauses with nominal predicates, which appear to have properties of both V-raising and Wh-raising clauses and are a potential challenge to the analysis. Section 7 concludes.

2 Wolof complementizers and subjects

In this section I discuss the properties of sentence particles, to show that they belong to the same category and can be treated as low complementizers. I then review the properties of subject clitics, arguing for their pronominal status. Finally, I address the status of non-clitic subjects in V-raising clauses and show that they are not in a canonical subject position.

2.1 Sentence particles and subject clitics

All finite indicative clauses in Wolof contain one of what appear to be a variety of sentence particles. My view of these elements broadly follows Dunigan's (1994) analysis, who argues that they belong to the same category (for her, SigmaP), as they are in complementary distribution with one another, and pronominal clitics behave uniformly with respect to them, clustering in a fixed order to their right. I treat sentence particles as low complementizers hosted by the head that combines the features of C and Infl, which I here call CI. (3) shows the clauses structure argued for in this paper. CI is sometimes realized as a single head, and sometimes split into two heads. Wolof

³The debate around the relationship between C and T is equally valid in languages in which inflectional features are not all grouped on one head, but spread out over more structure, as is the case in Wolof. Tense is here lower than the head hosting the subject. Since Wolof does not exhibit agreement with the subject, I label the head hosting the subject as Infl, and not Agr.

also possesses a higher embedding complementizer *ni*, which can embed a clause with any of the sentence particles.⁴

(3) Wolof clause structure

[_{CP-EMB} *ni* [_{TopP} [_{CIP} *sentence particles* [_{TP} [_{vP} []]]]]]]]]

Wolof has two finite indicative clause-types. In *V-raising* a verbal element is adjoined to the sentence particle, the clause-internal subject can only be a clitic, with an optional non-clitic subject in the left periphery (I shall argue in Spec,CIP). In *Wh-raising*, an XP is A'-moved to the specifier of the sentence particle, the verb does not raise to it, and the clause-internal subject can be a non-clitic. Table 1 summarizes these characteristics.

V-raising	Wh-raising
verb in CI	no verb in CI
lexical subject in Spec,CIP	A'-moved XP in Spec,CIP
subject below CI must be a clitic	subject below CI can be a non-clitic

Table 1: Syntactic characteristics of V-raising and Wh-raising clauses

V-raising clauses are exemplified in (4). Elements that can raise/adjoin to CI are the main verb, as in an information-structurally neutral clause in (4a), the verb *def* 'do' in a Predicate Focus clause in (4b), and the imperfective auxiliary *di* in (4c). I follow Church (1981) and consider Predicate Focus clauses to involve *do*-support. Since *def* 'do' never carries any inflectional morphology, I assume it is externally merged directly into CI.⁵

(4) V-raising clauses

- a. Xale yi lekk-**na**=ñu=ko=fa.
 child the.PL eat-C_V=3PL=3SG.OBJ=LOC
 'The children ate it there.'
- b. Xale yi **da**=ñu=ko=fa lekk.
 child the.PL do.C_V=3PL=3SG.OBJ=LOC eat
 'The children ATE it there.'
- c. Xale yi **di-**na****=ñu=ko=fa lekk.
 child the.PL IPFV-C_V=3PL=3SG.OBJ=LOC eat
 'The children will eat it here.'

⁴In a split-CP structure proposed by Rizzi (1997), CI would be closest to Fin, which is how Zribi-Hertz and Diagne (2002) and Torrence (2003) label the V-raising particle *na*. The embedding complementizer *ni* would be akin to Rizzi's Force.

⁵The sentence particle and the verb 'do' are not transparently decomposable into two separate morphemes. Church (1981) credits Senghor (1963) for the insight that these clauses contain the verb 'do', relating the third singular form of the complementizer+subject-clitic complex, which is *dafa*, to *def* 'do'. He notes that this link is clearer in some Wolof dialects, in which the 3rd singular form is *def-a*.

The clauses in (4) obligatorily contain a subject clitic right-adjacent to the sentence particle, and the non-clitic subject is to its left. Note also that all clitics cluster to the right of the sentence particle. Since clitics target a particular position in the clause, they are evidence that the different sentence particles are members of the same category and occupy the same syntactic slot. Clitics can surface elsewhere if the clause is smaller than a CP (see §6.2), but they only cluster, and surface in this particular order, to the right of a sentence particle.

In Wh-raising clauses—Subject and Non-subject Exhaustive Identification clauses, questions, and relative clauses—the non-clitic and the clitic subject are in complementary distribution below CI.⁶ In Non-subject extraction, the lexical subject and the pronominal one are clause-internal, to the right of the sentence particle, as in (5). (5a) and (5b) show a clause with Exhaustive Identification of the object. The clause-internal subject is either the clitic, or the non-clitic subject.⁷ (5c) and (5d) show the same for an object relative clause.

(5) *Object Wh-raising*

- a. Musaa_i l-a=ñu=fa gis t_i.
Moussa l-C_{Wh}=3PL=LOC see
‘It is Moussa that they saw there.’
- b. Musaa_i l-a=fa xale yi gis t_i.
Moussa l-C_{Wh}=LOC child the.PL see
‘It is Moussa that the children saw there.’
- c. jigéén_i j-i=mu=fa gis t_i
woman CM-C_{Wh}=3SG=LOC see
‘the woman that he saw.’
- d. jigéén_i j-i=fa Musaa gis t_i
woman CM-C_{Wh}=LOC Moussa see
‘the woman that Moussa saw.’

In subject *wh*-extraction, either the lexical subject or a subject pronoun is located in the specifier of the sentence particle.⁸ Neither can occur to its right. (6) shows this for subject Exhaustive Identification and a subject relative clause.

⁶Another clause-type that falls into the Wh-raising type are verbless clauses with locative predicates, in which the subject is A'-extracted. One type of a progressive clause is built on top of the locative clause, so it also belongs to the Wh-raising clause-type, though its syntax is a bit more complex. I therefore do not discuss it here, but see Martinović and Schwarzer 2018 for details.

⁷The clitic subject and the non-clitic subject are ultimately not in the same position; the clitic is right-adjacent to the sentence particle and followed by other pronominal clitics, whereas the non-clitic subject follows all pronominal clitics (Russell 2006; Martinović 2015a). The clitics therefore end up in a position right above the clause-internal subject position.

⁸Wolof distinguishes between strong pronouns and clitics, and their distribution differs. Only a strong pronoun can occur in Spec,CP (in line with observations made in Cardinaletti and Starke 1999). The pronouns in Spec,CP are reduced and in most persons identical to clitics. See Martinović 2015a for more detail.

- (6) Subject focus
- a. Ayda_i-a t_i dem.
 Ayda-C_{Wh} go
 ‘It’s Ayda who went.’
- b. Mu_i-a (>moo) t_i dem.
 3SG-C_{Wh} go
 ‘It’s her/him who went.’
- c. xale_i y-i t_i sopp Ayda
 child CM-C_{Wh} love Ayda
 ‘the children that love Ayda’

The difference between V-raising and Wh-raising clauses is very clear. In the former, the non-clitic subject and the subject clitic are on the opposite sides of the sentence particle. The clitic right-adjacent to it is obligatory, and the non-clitic subject occurs in the left periphery. In the latter, the lexical and the pronominal subject are either in complementary distribution clause-internally (to the right of the sentence particle), or in the specifier of the sentence particle, in which case a subject clitic cannot occur to its right. This distribution of subject clitics precludes an analysis in which they are verbal agreement, since we would have to contend with the obligatory absence of agreement in all but V-raising clauses.

To further support this claim, I discuss the properties of subjects to the left of the sentence particle in V-raising clauses, to show that they differ from clause-internal subjects and to establish their position in the left periphery.

2.2 Non-clitic subjects in V-raising

I have argued that the non-clitic subject is in different positions in V-raising and in Wh-raising clauses. Part of my analysis of the obligatory occurrence of the subject clitic in V-raising clauses relies on demonstrating that the non-clitic subject to the left of CI is not in a structural subject position; i.e. that this subject does not satisfy whatever requirement is placed on the subject of the clause. In this paper I argue that this requirement is that an element in the clause bear the nominative case, and that the subject to the left of CI cannot receive it. The subject clitic can, and therefore it is the only available subject in V-raising clauses. The details of this proposal are worked out in section 4. In this section, I establish the position of the non-clitic subject in V-raising clauses.

One possibility is that all subjects to the left of CI are topicalized. DPs can certainly be left-dislocated in Wolof and receive topical interpretation (Russell 2006). Topics in Wolof are resumed by clitics. Topicalized subjects can freely change order with other topics, confirming that they are indeed topicalized, as in the Wh-raising clauses in (7).

- (7) Topics can change order in Wh-raising clauses; Russell 2006, 130
- a. Ceeb bi_i [Maryam ag Xhadi]_j, ñu_j-a (>ñoo) ko_i lekk
 rice the.SG Maryam and Xhadi 3PL-C_{Wh} 3SG.OBJ eat
 ‘The rice_i, [Maryam and Xhadi]_j, it’s them_j who ate it_i.’

- b. [Maryam ag Xhadi]_j ceeb bi_i ñu_j-a (> ñoo) ko_i lekk
 Maryam and Xhadi rice the.SG 3SG-C_{Wh} 3SG.OBJ eat
 “[Maryam and Xhadi]_j, the rice_i, it’s them_j who ate it_i.”

In V-raising clauses, the same can happen – a subject in the left periphery can be topicalized, as shown in (8), where it can change order with the topicalized object DP.

(8) Topics can change order in V-raising clauses; Russell 2006, 130

- a. Ceeb bi_j [Maryam ag Xhadi]_i lekk-na=ñu_i=ko_j.
 rice the.SG Maryam and Xhadi eat-C_V=3PL=3SG.OBJ
 ‘The rice_j, [Maryam and Xhadi]_i, they_i ate it_j.’
- b. [Maryam ag Xhadi]_i ceeb bi_j lekk-na=ñu_i=ko_j.
 Maryam and Xhadi rice the.SG eat-C_V=3PL=3SG.OBJ
 ‘[Maryam and Xhadi]_i, the rice_j, they_i ate it_j.’

Topicalized DPs are usually followed by a pause, and must be felicitous under a topical interpretation. The same is not true of lexical subjects in V-raising structures. The sentence in (4a), for example, can be uttered in an out-of-the-blue context, and the DP *xale yi* ‘the children’ is not followed by a pause. A more convincing piece of evidence that there is a difference between pre-CI lexical subjects in V-raising clauses and topicalized DPs comes from bare quantifiers, which are usually assumed not to be able to occur in topic position (Rizzi 1986, 1997). This is true in Wolof: as expected, bare quantifiers cannot occur in positions which are definitely topics, such as preceding elements that A'-move to Spec,CIP:

(9) Bare quantifiers cannot precede A'-moved elements; Russell 2006, 134

- *Kenn_i lan l-a=∅_i jënd?
 someone what l-C_{Wh}=3SG buy
 intended: “Someone, what did s/he buy?”

Russell (2006) shows that in Wolof bare quantifiers can appear as subjects to the left of CI, as in (10a), but not as subject topics, in (10b):

(10) Bare quantifiers can be to the left of C in V-raising; Russell 2006, 134

- a. Kenn_i gis na=∅_i Maryam.
 someone see C_V=3SG Maryam
 “Someone_i saw Maryam.”
- b. *Kenn_i Maryam_j gis na=∅_i=ko_j.
 someone Maryam see C_V=3SG=3SG.OBJ
 intended: “Someone_i, Maryam_j, s/he_i saw her_j.”

The data suggest that there is a non-topical position for non-pronominal subjects to the left of the sentence particle in V-raising clauses. I propose that this is the specifier of the CI head. One crucial difference between the subject position in V-raising clauses and the one in Wh-raising

clauses is that the former one does not have to be occupied by an overt element. Clause internal subjects, on the other hand, can never be null.

(11) Only subjects to the left of C can be null

- a. (Xale yi) lekk-na=ñu ceebujën.
(child the.PL) eat-C_V=1 SG ceebujen
'(The children)/They ate ceebujen.'
- b. Ceebujën la *(xale yi/ñu) lekk,
ceebujen C_{Wh} *(child the.PL/3PL) eat
'It's ceebujen that {the children/they} ate.'

Furthermore, the subject in V-raising clauses can be a strong pronoun. As in many languages that have both strong and weak/clitic pronouns, strong pronouns in Wolof cannot occupy argument positions; they can be topicalized, focused, and found in coordination and as complements of prepositions (Cardinaletti and Starke 1999). They can also occupy the subject position to the left of C in V-raising clauses:

(12) Only subjects to the left of C can be strong pronouns

- a. (Ñoom) lekk-na=ñu ceebujën.
(3PL.STR.PRON.) eat-C_V=1 SG ceebujen
'They ate ceebujen.'
- b. *Ceebujën la ñoom lekk.
ceebujen C_{Wh} 3PL.STR.PRON. eat
'It's ceebujen that they ate.'

I argue in this paper that the non-topical subject position in V-raising clauses differs from the clause-internal subject position in Wh-raising clauses in that the former one is not a structural case position, while the latter one is. This will play an important role in explaining the obligatory presence of the subject clitic in V-raising clauses.

2.3 Interim summary

In this section we saw data that point to a structural difference between V-raising and Wh-raising clauses in Wolof. The highest functional head in V-raising is doing double duty: it has a C-like property, in that it hosts the complementizer *na*, and an Infl-like property, in that it hosts the subject in its specifier. In Wh-raising clauses, there are two separate heads, a higher C-like one that hosts the *wh*-complementizer (Martinović 2015a, 2017b,a) and a *wh*-word in its specifier, and a lower Infl-like one that can host a non-clitic subject in its specifier. The main claim of this paper is therefore that in Wolof the features of C and Infl are sometimes contained in one head (non-cartographic effects, in (13)), and other times split over two heads (cartographic effects, in (14)).

(13) V-raising

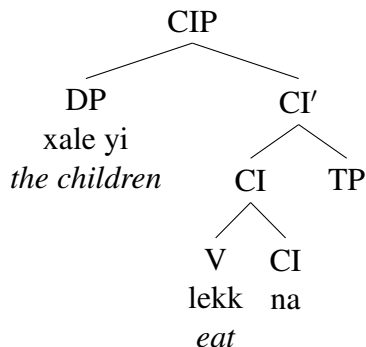

(14) Wh-raising

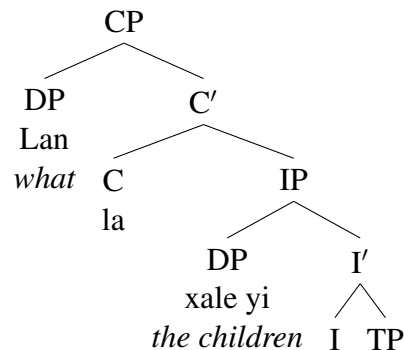

We also saw that clauses with a compact CI head contain an obligatory subject clitic to the right of CI, in addition to the (optional) non-clitic subject in Spec,CIP. I will argue that this has to do with (i) the requirement that every clause have a nominative subject, and (ii) the inability of the non-clitic subject in Spec,CIP to receive nominative case.

The next section presents the mechanism of *Head-splitting*, which is used to derive the difference between V-raising and Wh-raising clauses.

3 Head-internal geometry and head-splitting

In this section, I lay out the mechanism which derives the non-cartographic V-raising clause type, in which features are bundled on one head, and the cartographic Wh-raising type, in which they are distributed over two heads. I propose that splitting of features across two heads occurs in cases of feature-checking failure, e.g. due to the goal not being in the probe's c-command domain or due to the unavailability of a landing position for the movement of the goal. In such a case, the part of the head containing this feature's node may alternatively move to a higher position, creating new c-command relations and a new specifier position, yielding what we traditionally observe as C and Infl separation.

First, I adopt the standard assumption that there are two types of features: (i) Probe-features that trigger syntactic operations such as agreement and movement because they must be checked by forming a relationship with an element that carries (ii) a matching Goal-feature ($[F^+]$). I propose that there are two types of Probe-features, listed in (15):

(15) Probe feature-types

- a. **Type 1** Probe-features $[F^*]$ on X are checked (i) by agreement and movement of Y/YP with a matching Goal-feature $[F^+]$ such that X c-commands Y/YP, or (ii) by base-generation of a Y/YP with $[F^+]$ in Spec,XP or adjoined to X.
- b. **Type 2** Probe-features $[F^\circ]$ on X are checked by Y with a matching Goal-feature $[F^+]$ such that Y c-commands X, under the locality condition defined in (16).

(16) Locality Condition for Type 2 feature-checking⁹

A Type 2 Probe-feature F° on a head X is checked by a Goal-feature F^+ on a head Y,

⁹The Locality Condition as defined here is akin to proper head-government (Chomsky 1986).

such that Y c-commands X and there is no head Z such that Z c-commands X and Y c-commands Z.

In this paper, the only Type 2 feature we will concern ourselves with is the Case⁰ feature. See Martinović 2015a for arguments that φ -feature in Wolof is also a Type 2 feature.

Probe-features on a head are hierarchically organized in a type of a feature-geometry, in which each feature is realized as a separate node, illustrated in (17).

(17) $[_H F1^* [_H F2^* [_H F3^\circ [_H H]]]]]$

All features are checked in a strict order, determined by the head-internal geometry. Note that the structural conditions on feature checking are placed on the head, and not on the node where a particular feature is located. The head probes for elements with matching features, based on the accessibility condition in (18). The only feature accessible to the head and capable of triggering operations is the highest unchecked feature in the hierarchy.

(18) *Feature Accessibility Condition*

An unchecked feature F^*/F° on a head X is accessible to syntactic operations only if F^*/F° is the highest unchecked feature in the hierarchy.

In addition to Probe-features, a head may, of course, also contain Goal-features. I propose that they are accessible at any point in the derivation by another head for feature-checking purposes. For concreteness, I place goal features in the lowest nodes of a particular head.

The feature system I propose is in several ways similar to the system in Georgi and Müller (2007, 2010) and Müller (2010). They propose the existence of two types of features: subcategorization features, which are involved in structure-building and trigger external Merge, and probe features, which trigger Agree under c-command. Their subcategorization features either have θ -roles mapped onto them, or play a role in structure-building operations that involve functional categories. My Type 1 and Type 2 features would both be a type of a probe feature in a system such as the one in Georgi and Müller 2007, 2010 and Müller 2010. I do not include subcategorization features in my model, as they are not directly relevant for the present topic, but their checking could not be assimilated to either that of Type 1 or Type 2 features, since subcategorization features need to be able to create both complements and specifiers. I leave the question of how subcategorization features fit into the feature-system I propose aside for the time being.

A further difference from the system I propose and that of both Georgi and Müller and the nowadays more common systems with the uninterpretable/interpretable distinction (e.g. Chomsky 1995; Pesetsky and Torrego 2001, 2007) is in the direction of the operation Agree. The original definition of Agree states that a probe searches for a goal in its c-command domain, meaning that agree can only proceed DOWNWARD (Chomsky 2000, 2001; see also, among others, den Dikken 1995; Polinsky and Potsdam 2001; Preminger 2013; Polinsky and Preminger To appear). This view of agreement has been extensively challenged, proposing that a goal can also (or only) be higher than the probe, resulting in UPWARD agree (Merchant 2006, 2011; Baker 2008; Bjorkman 2011; Wurmbrand 2012a,b, 2014; Zeijlstra 2012; Abels 2012; Bjorkman and Zeijlstra 2014, 2015, 2019; Carstens To appear). In my system, movement-triggering Agree is initiated by Type 1 features and proceeds downward, i.e. the probe c-commands the goal. Type 2 features do not trigger movement, but initiate Agree only with a goal that c-commands them, in an instance of upward agreement

(Merchant 2011). This points to a crucial difference between the two feature types in their role in syntax.

Another question we might ask is how we can tell that a particular feature is ever valued without triggering movement, if it is valued by a higher goal. The idea that a probe agrees with a higher goal is crucially tied to proposals that, at least for some agreement relationships to be established, the Spec-Head configuration is necessary (e.g. Koopman 1996, 2005; Chung 1998). This is usually handled by assuming that one and the same feature triggers agreement and movement. In Wolof, however, we have no evidence of, for example, φ -agreement between the subject and the verb (T), but the subject does move out of its base position. The only instance of agreement in φ -features occurs in a subset of A'-movement constructions, between the head hosting the sentence particle, and the A'-extracted phrase (not necessarily the subject). In Martinović 2015a I therefore propose that φ is a Type 2 feature, never triggering movement, but only agreeing if there is an available goal that locally c-commands it. I do not discuss φ -features in this paper, but I consider Case⁰ to be a Type 2 feature that is checked by a locally c-commanding goal. This will explain why only a clitic subject is acceptable in V-raising clauses.

An important part of the feature-system that I propose is that Probe features on a head are hierarchically ordered. The hierarchical ordering of features is not a novel idea and has been explored in various works. Georgi and Müller (2007, 2010) and Müller (2010) assume that their subcategorization features and probe features form strictly ordered stacks on a head and must be *discharged* hierarchically, by invoking the same type of accessibility restriction that I propose – only features that are on top of a feature stack are accessible. Another proposal of hierarchical feature ordering is made by Manetta (2006, 2011), who posits that features on a head have internal organization. First, they are grouped into bundles, and then those bundles form ordered stacks. Each bundle is valued in a single Probe-Goal interaction. The difference between these models and the one I propose is that I assume that features are hierarchically organized as terminal nodes of a complex head.¹⁰ This has the advantage of affording a straightforward way for a part of the head to split off and reproject to a higher position, which is how I propose the C-I system is formed.

I propose that Head-Splitting may apply in building of a structure as defined in (19):

(19) Head-Splitting

The smallest projection of the head H that dominates all unchecked features splits off and moves to a higher position, adjoining to HP.

The trees in (20) and (21) illustrate the geometrical feature organization on the head H, and the splitting mechanism. In (20), [F1*] is checked first by agreement with, and movement of, some element in H's c-command domain (not shown). When the turn comes for [F2*] to be checked, this fails (one reason for feature-checking failure is discussed below). Another possible derivation is for [F2*] and the projection immediately dominating it to split off and remerge above H, thus creating a new head.

¹⁰Geometrical organization of features has been proposed, though in a more complex form, in Harley and Ritter 2002.

(20)

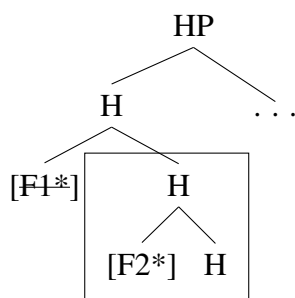

(21)

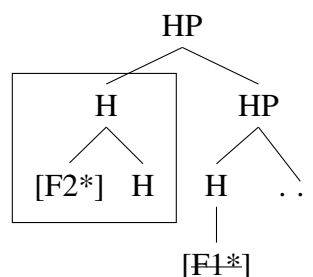

Head-splitting is similar to head reprojection (e.g. Pesetsky 1985; Ackema et al. 1993; Koenenman 2000; Haider 2000, 2005; Bhatt 2002; Hornstein and Uriagereka 2002; Fanselow 2003; Surányi 2005; Georgi and Müller 2010), except that here only parts of heads reproject – those that carry unchecked features. Reprojection provides a natural way of deriving Head-Splitting, if we allow for only parts of heads to reproject. This is the novelty of my approach, made possible by the geometrical organization of a head’s Probe-features. A question we may want to ask at this point is how this system would derive the data from, for example, West Germanic and Kinande, in which we do see φ -features appear on both the C and the T head. It can be imagined that in such languages the features that are duplicated are not geometrically organized, but are organized in a manner closer to that proposed in Georgi and Müller 2010, with entire heads reprojecting. Since this is not the case in Wolof, I do not directly address this question here, but see Erlewine 2018 for an implementation of this idea.

4 V-raising and unsplit CI

Together with sections 5 and 6, this section develops the central argument of the paper: that the C-I link in Wolof is of a particular nature, namely, that the two heads traditionally called C and I in fact start out as a single head, which may remain compact in Wolof.

Here we take a close look at V-raising clauses.¹¹ The data in §2 illustrate three crucial properties that differentiate them from Wh-raising clauses, repeated in Table 2. First, in V-raising clauses the verb is located in the highest head, which also hosts the sentence particle. Second, the optional lexical subject is to the left of the verb-C-clitic complex. And third, there is an obligatory clitic subject, right-adjacent to the sentence particle.

V-raising	Wh-raising
verb in CI	no verb in CI
non-clitic subject in Spec,CIP	A'-moved XP in Spec,CIP
subject below CI must be a clitic	subject below CI can be a non-clitic

Table 2: Syntactic characteristics of V-raising and Wh-raising clauses

There are two types of V-raising clauses: those with a verb or the imperfective auxiliary in CI, Neutral sentences, and those with *do*-support in CI, Predicate focus sentences (see §2). I argue

¹¹“V-raising” is somewhat of a misnomer since one clause-type involves *do*-support – the verb *def* ‘do’ is inserted directly into CI. I use the term “V-raising” for convenience.

here that they involve an unsplit CI head. I also propose that the clause-internal subject can only be a clitic because of the mechanism of Nominative Case assignment.

I propose the CI head in V-raising structures in Wolof to have the following features:¹²

(22) Features of CI in Wolof V-raising clauses

- (i) D*
- (ii) V*
- (iii) Case⁺

D* is a Type 1 Probe-feature, more commonly known as the EPP, traditionally used to capture the observation that there is an overt subject, at some point in the derivation, in Spec,IP (Chomsky 1982). There have been many attempts to reduce the EPP to other phenomena, which either cluster with the EPP, or are meant to explain its effect and make it superfluous.¹³ Acknowledging all the unresolved questions related to the EPP, I adopt the proposal in Chomsky 1995 that EPP is a D feature on CI.

V* is also a Type 1 Probe-feature; I hold it responsible for verb raising to CI. In some analyses, especially of V2 languages, the feature that performs this function is a Tense feature (e.g. Den Besten 1989). I argue in Martinović 2017a that Tense is below CI in Wolof, and therefore could not trigger verb raising to CI. V* has no explanatory power here; I use it simply to capture verb movement up the clausal spine.

Another relevant feature is the Type-2 feature on a DP, requiring that it be assigned case. I am here agnostic as to whether this feature can be reduced to another feature, and label it simply as Case^o. The goal feature is Case⁺ on CI, which I propose assigns nominative case, under the Locality Condition defined in (16). This will account for the obligatory presence of a subject clitic in V-raising clauses.

The internal feature geometry of CI is represented in (23).

(23) Feature geometry of CI in V-raising clauses

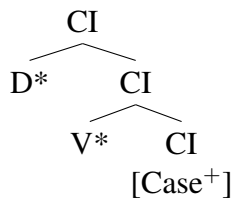

In the remainder of this section, I show how the feature geometry of CI and the system detailed in the previous section derive three properties of V-raising clauses: (i) a verb is located in the highest functional head (ii) a non-clitic subject is in the specifier of this head, and (iii) a subject clitic obligatorily occurs to the right of this head. We will consider the derivation of Neutral clauses, but Predicate focus clauses are derived in the same way, the only difference being that V*

¹²The feature structure also contains a φ^o -feature, which I consider a Type 2 feature. Since this paper does not discuss φ -feature agreement in Wolof, I omit it here for simplicity. For more, see Martinović 2015a, 2017b.

¹³E.g. Case theory, as in Grohmann et al. 2000 and Bošković 2002; PF requirements, as in Holmberg 2000, Bobaljik 2002, Landau 2007, and others; semantic requirements, Rothstein 1983, etc.

on CI is satisfied via the external merger of the verb *def* 'do', instead of the internal merger of a verbal head from the clause.

A simplified structure of the V-raising clause in (24) (omitting functional projections irrelevant for the analysis) when CI is merged is in (25).¹⁴ I assume that the verb raises through all the heads of the inflectional layer to T, triggered by the V*-feature. CI takes the TP as a complement. Note that the subject DP cannot have its Case^o feature checked in this position. Case^o is a Type 2 feature, and must be checked via a c-commanding head in a local configuration. In (25), the subject DP is separated from CI by the TP.

- (24) Xale yi lekk-na=ñu ceeb.
 child the.PL eat-C_V=3PL rice
 "The children ate rice."

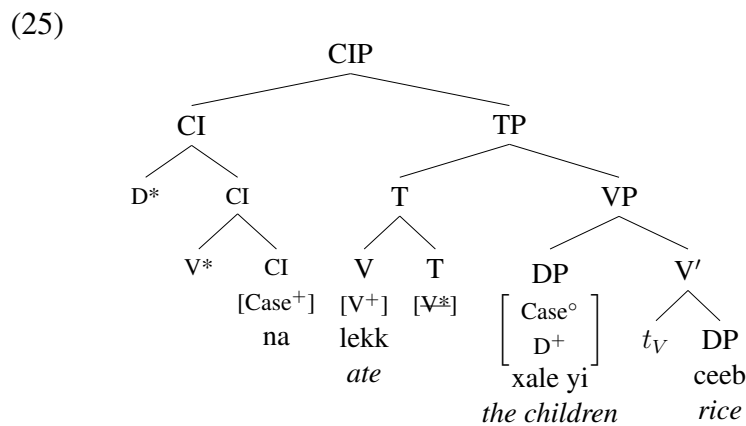

As laid out in detail in section 3, Probe-features on CI are checked by an element with a matching Goal-feature, according to the order imposed by their hierarchical organization and in accordance with the *Feature Accessibility Condition* in (18). The first accessible feature is D*, a Type 1 feature that must be checked via Agree and Move, so the subject *xale yi* 'the children' moves to Spec,CIP to check D* on CI. Recall from section 2 that the non-clitic subject in V-raising clauses is not a topic, as it can be a bare quantifier, and that it occupies a position below topics. I therefore propose that it is located in Spec,CIP. The next accessible feature is V* and the verb *lekk* then moves and adjoins to CI to check it.¹⁵ The derivation is illustrated in (26).

¹⁴I use smaller font to distinguish the internal syntax of the CI head from the remainder of the clausal structure.

¹⁵In this analysis, head movement and phrasal movement are crucially different, in that heads adjoin to heads and phrases move into their specifiers (c.f., e.g., Matushansky 2006.).

(26)

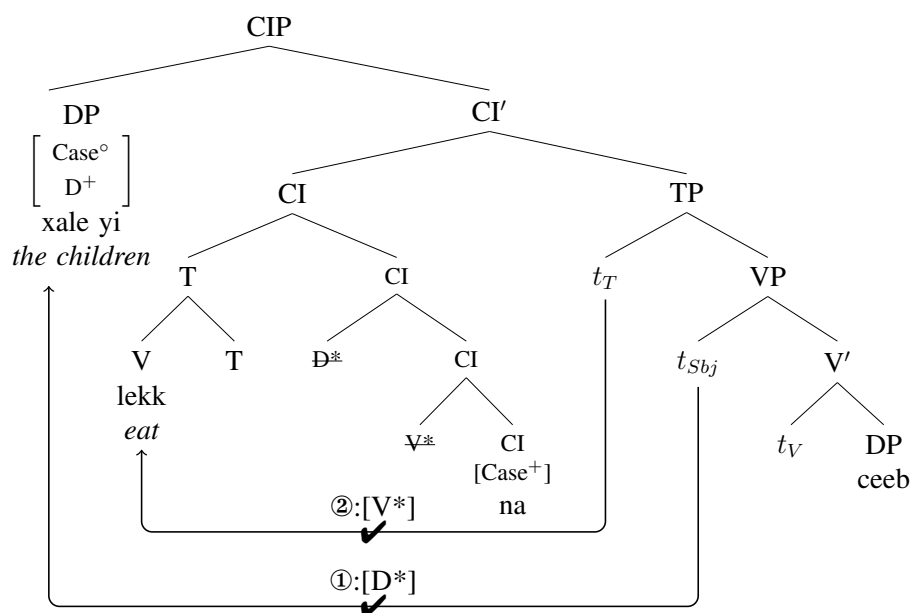

The internal feature geometry of the CI head and the hierarchical valuation of features explains why the CI head in V-raising clauses is not split, deriving the fact that a non-clitic subject does not occur below CI in these sentences. (26) is, however, not the final structure of a neutral V-raising clause; we have seen that these clauses have an obligatory subject clitic right-adjacent to the CI head:

- (27) *Neutral V-raising clause has an obligatory subject clitic*
Xale yi lekk-na=*(ñu) ceeb bi.
child the.PL eat-C_V=3PL rice the.SG
“The children ate the rice.”

I propose that Spec,CIP is not a position where the subject can get nominative case. This is supported by the fact that it can be occupied by strong pronouns, which can never be found in structural case positions. Furthermore, I propose that its case can also not be checked in a position below CI. The locality condition on the checking of Type 2 features requires them to be checked by a local c-commanding head. The subject DP and CI are at no point in the derivation in such a configuration. Before movement to Spec,CIP, the subject is not local enough to CI to have its Case°-feature checked; after movement, the case-assigner no longer c-commands it.

I propose that the occurrence of the subject clitic is related to the following requirement:

- (28) *Nominative Case Condition*
Nominative case must be assigned to some nominal element in every finite clause.

Given that a non-clitic DP can in no circumstance get nominative case, I propose that the derivation in which only a non-clitic subject is generated in Spec,VP always crashes.

The alternative is for the clause-internal subject to be a clitic. Because clitics in Wolof move to a particular position in the clause, the subject clitic will adjoin to the sister of the complement of the highest functional head in the CIP domain (see (30)). This happens to be the position that

satisfies the locality requirement for Type 2 feature-checking, enabling a pronominal subject to have its Case^o-feature checked. I propose this to be the reason why V-raising clauses can only have a pronominal clause-internal subject.¹⁶

What remains now is to formalize the relationship between the clitic and the non-clitic subject, capturing the fact that a non-subject DP cannot occupy Spec,CIP. I propose that this is a type of Clitic Doubling/Clitic Left Dislocation. For concreteness, I propose that clitics are generated as a constituent with a doubled argument in a *big-DP* structure as in (29) (Uriagereka 1995; Cecchetto 2000; Belletti 2005; Franks and Rudin 2005; van Craenenbroeck and van Koppen 2008; Arregi and Nevins 2012). Clitics in Wolof behave more like phrases than like heads, so I place them in a specifier of D_{Big}, which takes the doubled argument as its complement. The doubled argument can be any DP or a strong pronoun, one of which is a *pro*. This explains why only a subject to the left of the sentence particle can be phonologically null: strong pronouns cannot occur in argument positions.

(29) big-DP

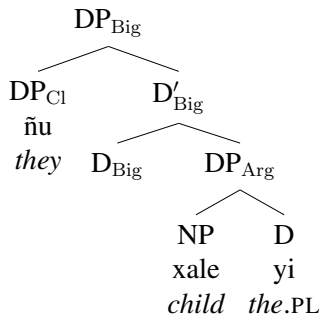

In Wolof, as in some other languages with Clitic Left Dislocation (but not Clitic Doubling, e.g. Italian), the clitic and DP_{Arg} cannot both stay clause-internal (inside the same CIP). The clitic has its own placement requirements, which have it adjoin to the sister of CI. If there is an overt argument inside the *big-DP*, it must be to the left of CI. In V-raising clauses, this position is Spec,CIP. I

¹⁶A similar phenomenon occurs in French Complex Inversion constructions. In the sentences in (i), a full DP subject precedes the verb, and a subject clitic follows it. As in Wolof, the preverbal subject can be a quantifier, meaning it is not in a dislocated position. Such structures are only available in questions in French.

(i) Complex Inversion in French (Rizzi & Roberts 1996, p.91)

- a. Quel livre Jean a-t-il lu?
 which book John has-t-he read
 “Which book has John read?”
- b. Personne n’est-il venu?
 no-one isn’t-he come?
 “Didn’t anyone come?”

Rizzi and Roberts (1989/1996) tie these constructions to case, though with slightly different assumptions. They propose that sentences as in (i) are clauses with two subjects (the clitic generated in Spec,TP and the DP in Spec,VP). They assume that T in French can only assign nominative case to the left, so if the verb stays in T, the subject in Spec,VP cannot receive case, and such sentences never surface. The raising of the verb to C makes two operations possible: (i) the lexical subject can move to its left and be assigned nominative case there and (ii) the subject clitic can receive case through incorporation into C (Baker 1988).

propose DP_{Arg} moves there to check D^* . Since only a subject can occupy Spec,CIP (the object, for example, cannot move there), it follows that the subject in V-raising clauses is always a *big*-DP, with the double being the highest DP and thus moving to Spec,CIP.¹⁷ I defer a detailed discussion of clitics until section 6.

The final structure of the V-raising clause is in (30). The clitic is in its final landing position, adjoined to the sister of CI, where it can receive nominative case.¹⁸

(30)

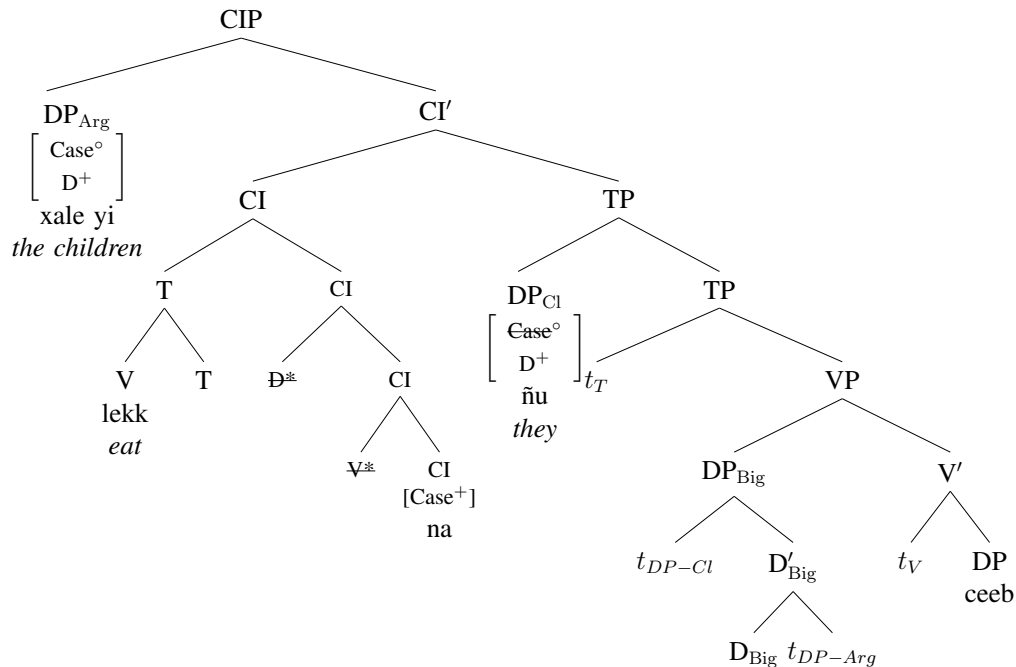

A final detail has to do with case of DP_{Arg} . I have argued that only the clitic can receive case in V-raising clauses, given its placement in the position where it is locally c-commanded by CI. This would mean that DP_{Arg} does not get nominative case. There is no overt case marking in Wolof, and only clitics show a difference between nominative and accusative case; strong pronouns do not. It has been proposed that, in cases in which a DP cannot be assigned abstract case—for example, when it is left-dislocated—it receives default morphological case (e.g. Anagnostopoulou et al. 1997; Legate 2008). I adopt this proposal for our purposes.

In this section I investigated V-raising sentences in Wolof, which exhibit three properties not found in Wh-raising sentences. First, the verb is located in the head that hosts the sentence particle, a complementizer-like element by hypothesis situated in a C-like head. Second, the non-clitic subject cannot be below the sentence particle, but is located to the left of the verb-C complex. And third, an obligatory pronominal subject clitic occurs clause-internally, immediately to the right of

¹⁷An alternative to a *big*-DP would be to say that the DP in Spec,CIP is base-generated there. In that case, we must stipulate that a DP in Spec,CIP (and a DP in a topic position, for that matter) is obligatorily resumed by a clitic clause-internally. We also must place a condition on this DP, which would require it to bind the highest clitic in the clause, ensuring that the element in Spec,CIP is always the subject.

¹⁸Alternatively, Platzack and Holmberg (1995) propose that pronouns have inherent case, so clitics would do not need to have a $Case^0$ -feature checked.

the sentence particle. I argue that V-raising clauses contain one high functional head, CI, which combines features commonly distributed between C and I: two Type 1 features, D* and V*, which must be checked by an element in the c-command domain of CI that must move to its specifier or adjoin to it. Assuming a difference between head movement and phrasal movement, all of CI's features can be checked on CI, which leads to it staying compact. The obligatory occurrence of a pronominal subject clitic is the result of the mechanism of nominative case assignment, and the Nominative Case Condition, which requires that some nominal in a finite clause be assigned nominative case. I propose that it must be checked by CI in a configuration in which CI locally c-commands D. Such a relationship is never established between the lexical subject and the CI – when in situ, the lexical subject is divided from CI by other functional projections, at least the TP, and when to the left of CI, it is not c-commanded by it. Therefore, a derivation in which a lexical subject is generated in Spec,vP always crashes. If, however, a *big*-DP is generated in Spec,vP, containing both the clitic and the non-clitic subject, both D* and the Nominative Case Condition can be satisfied. The clitic raises via Clitic Movement and adjoins to the sister of the complement of the highest functional projection, which is just below CI. This position satisfies the requirement for nominative case assignment, and a pronominal clitic can thus receive nominative case. A lexical DP subject or a strong pronoun (which includes *pro*) moves to Spec,CIP to check D*.

In the following section, we explore Wh-raising clauses in which the CI head does not stay compact, but splits into two positions, yielding the traditional C-I separation.

5 Head-splitting in Wh-raising clauses

Section 4 shows how a particular implementation of the insight that the complementizer layer and the inflectional layer share a deep connection, in an analysis according to which they start out as a single head, explains syntactic properties of V-raising clauses, in which there is no apparent division between the two heads and all their properties are bundled in one functional projection. In this section, I show how the same approach derives Wh-raising clauses, where the traditional division between the two heads is observed. The crucial difference between the two clause types is in the availability of a subject position below the sentence particle, i.e. the CI head.

Wh-raising clauses include *wh*-questions, structures in which a DP is Exhaustively Identified, and relative clauses. We will limit our discussion to *wh*-questions in this paper, but the analysis extends to all A'-movement constructions.¹⁹

The feature structure of CI in Wh-raising clauses differs from the one in V-raising clauses. Obviously, there is a Wh*-feature present. However there is also a feature that is absent – the V*-feature, since in A'-movement constructions the verb does not raise to CI. In other words, V-to-C and *wh*-movement are in complementary distribution. For reasons of space I do not discuss this interesting fact here, but see Klecha and Martinović 2015 for some preliminary discussion of this, and a proposal that Wh* and V* are two sides of the same feature.

¹⁹There are two types of *wh*-questions in Wolof, which on the surface appear to be different. In Martinović 2017b I claim extensively that all A'-movement constructions in Wolof have the same syntax, and that their surface appearance is the result of postsyntactic processes.

(31) Feature geometry of CI in Wh-raising clauses

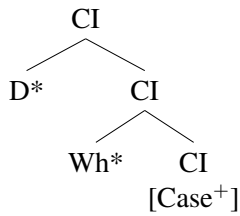

We start with non-subject extraction. The Wh-raising clause in (32) has the structure in (33) after the subject moves to check D*.

- (32) Lan la xale yi lekk?
 what C_{Wh} child the.PL eat
 “What did the children eat?”

(33)

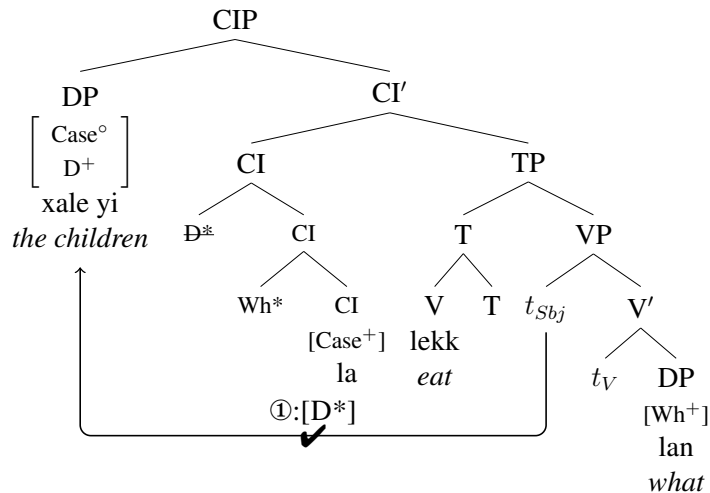

The next feature to be checked is Wh*, which, being a Type 1 feature, also requires a DP with the corresponding feature to move to Spec,CIP. This, however, is an illicit construction in Wolof; an object *wh*-question can have neither the form in (34), nor, for example, one in which the *wh*-phrase tucks in between the subject and CI, in the sense of Richards (1997, 1999). I take this to mean that two specifier positions to CI in Wolof are disallowed.

(34) *

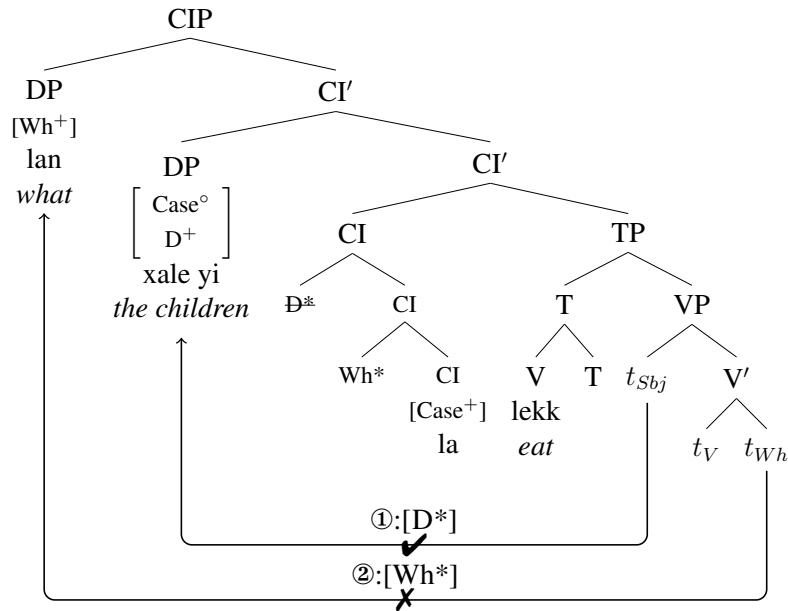

I propose that there is another way to derive the desired structure, by employing Head-Splitting, defined in (19) and repeated here in (35):

(35) Head-Splitting

The smallest projection of the head H that dominates all unchecked features splits off and moves to a higher position, adjoining to HP.

In the present example, this means to split off the node dominating Wh*, and remerge it in a higher position, thus forming a new head, as in (36).

(36)

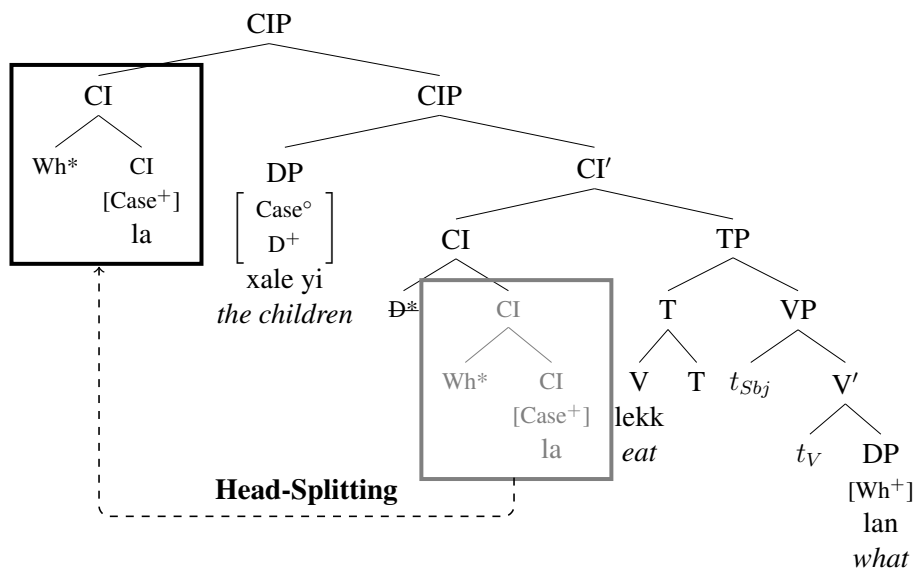

[Wh*] now probes again, from its new position, and can be checked by the movement of the object

wh-phrase *lan*:

(37)

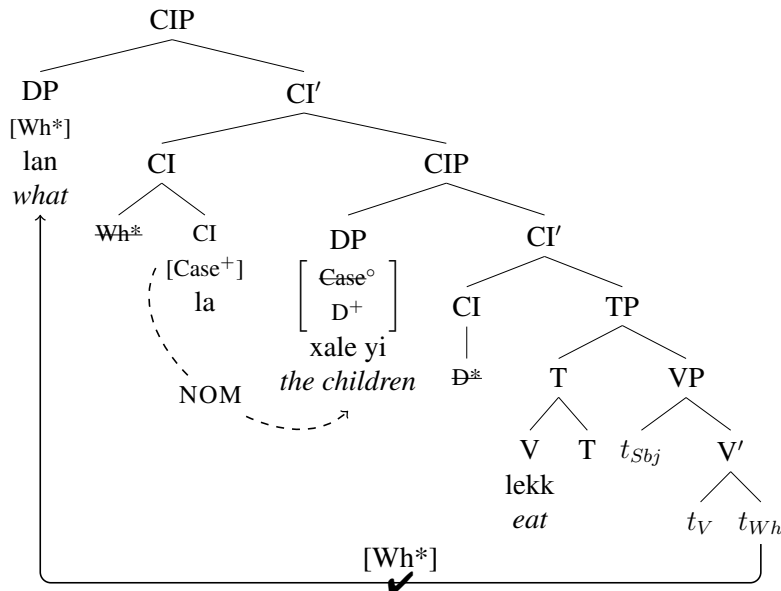

As can be seen in (37), another feature is checked in this configuration – the Case° feature on the subject DP. Recall that no subject clitic co-occurs with a non-clitic subject in *Wh*-raising clauses. I propose this to be the result of Head-Splitting itself. Namely, when part of the CI head splits off and remerges by adjoining to CIP, it now locally c-commands the subject DP, located in Spec,CIP where it checked D^* . Under my assumption that nominative case is assigned in precisely this configuration, the subject DP can now receive it. This readily explains the availability of a subject position below CI in *Wh*-raising clauses, as opposed to *V*-raising ones, and thus the possibility to have a non-clitic subject in this clause-type.

Wh-raising clauses then contain a split CI head, yielding the more traditional separation of the projection hosting the complementizer and the projection hosting the subject. Head-Splitting in this case occurs because of a feature-checking failure; namely the Wh^* -feature on CI cannot be checked because there is no available position for the *Wh*-phrase to move into, since the subject is already moved into Spec,CIP to check D^* .

There is a worry that Head-Splitting as it is presented here necessarily involves some type of look-ahead, because an attempt to check Wh^* must first be made, and be filtered out by the ban on two specifiers. Head-Splitting would then be a last-resort, repair mechanism, which would entail undoing the illicit *wh*-movement step. One way to get around this would be to allow Head-Splitting to apply at any point in the derivation, meaning that every feature may split off and reproject. Derivations containing unwarranted instances of Head-Splitting (i.e. those that are not licensed by a failure in the derivation), would then be filtered out by a general Economy condition, favoring phrase markers that check as many features as possible in the smallest span of structure, instead of forcing vacuous movement.

Next, we look at an example of subject extraction, in (38). The derivation proceeds as for non-subject extraction up to the checking of the Wh^* -feature. The derivation with the subject moved to Spec,CIP to check D^* is given in (39).

- (38) Kan a lekk gato bi?
 who C_{Wh} eat cake the.SG
 ‘Who ate the cake?’

(39)

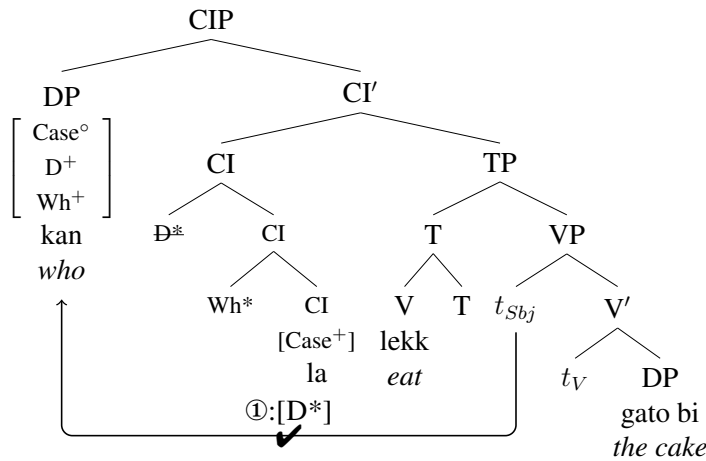

The next feature that probes is the Wh*-feature, but there is no goal with a matching feature in its c-command domain, given that the subject is already in Spec,CIP. Again, the option to split the CI head is available, which creates a new c-command domain that now contains the subject wh-phrase. The splitting also allows for the subject to receive nominative case, allowing for clauses with subject A'-movement to have non-clitic subjects. The final structure of (38) is in (40).

(40)

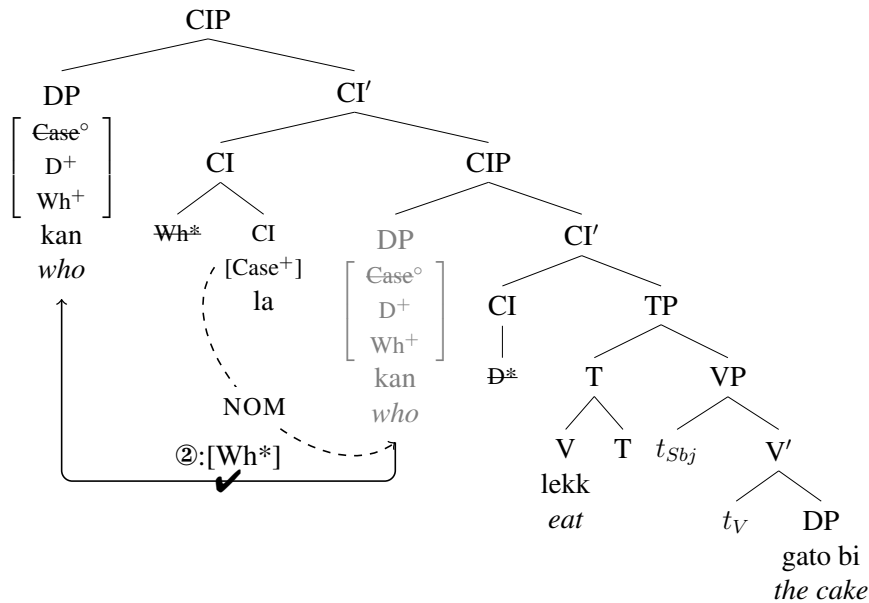

In this section, I argued that Wh-raising clauses in Wolof have a split CI head, resulting in a structure with the traditional distinction between a higher head (C-like), hosting a *wh*-element, and a lower head (T/Infl-like), with the structural subject in its specifier. This accounts for the key

difference between V-raising and Wh-raising clauses – the obligatory clitic clause-internal subject in V-raising clauses, due to the fact that there is no position in which a non-clitic subject can get nominative case (while a pronoun can do so by cliticizing below CI), and the availability of a clause-internal non-pronominal subject in Wh-raising, due to the fact that CI splits, and gets into a position from which it can assign case to the subject in the specifier of the lower CI. I proposed Head-Splitting to be the result of one of two situations that occur in the course of the derivation. In subject extraction clauses, at the moment when Wh* searches for an element with the Wh⁺-feature in its c-command domain, the subject DP is already located in Spec,CIP, and is therefore not visible to CI. Head-splitting creates a new c-command domain, and Wh* can now find the subject DP. In non-subject extraction, due to the fact that the subject first moves to Spec,CIP to check D*, and under the hypothesis that CI allows for only one specifier position, the object with the Wh⁺-feature has nowhere to move to. Wh* can again not be checked, so the derivation with Head-Splitting, which has another specifier position, is the one that does not crash.

In the following section we turn to clauses with nominal predicates which present an interesting puzzle for the analysis argued for thus far, in that they appear to have some properties of V-raising clauses, and some properties of Wh-raising clauses. I show how a deeper understanding of the syntactic behavior of clitics can help us make sense of these constructions.

6 The syntax of CI with nominal predicates

Clauses with nominal predicates are a big topic in syntax and semantics, as many of their properties are puzzling. I do not directly deal with most questions that research on copular sentences usually centers on, but focus on Wolof-particular peculiarities, showing how clauses with nominal predicates fit into and inform the analysis presented thus far.²⁰ Even though not all clauses with nominal predicates have a copular verb (in fact, the key structure we are interested in does not), I refer to these structures as *copular sentences* for convenience. I start with an overview of the data and the issues to be discussed in this section.

6.1 Copular sentences: Wh-raising with clitic subjects

Copular sentences in Wolof present a potential puzzle for the analysis thus far. A predicational, information-structurally neutral sentence, as in (41), appears to have properties of both V-raising and Wh-raising structures. On the one hand, it contains the sentence particle *la*, which occurs in Wh-raising clauses, in non-subject A'-extraction (see section 5), and the predicate DP A'-moves to its specifier, as I show below. On the other hand, the clause-internal subject is obligatorily a clitic, just as it is in V-raising and quite unlike what we have seen in Wh-raising clauses. An optional lexical subject is located to the left of the predicate DP, similar to what we saw in V-raising clauses.

²⁰For an excellent overview of various issues in the syntax and semantics of copular sentences, see Mikkelsen 2005. For a more detailed discussion of various types of copular sentences in Wolof, see Martinović 2015a. For a descriptive overview and a discussion of some of their information-structural properties see Martinović 2013, 2015b.

- (41) Affirmative copular sentence
 Xale yi sàcc la=*(ñu).
 child the.PL thief C_{Wh}=3PL
 “The children are thieves.”

Table 3 summarizes the relevant properties of V-raising and Wh-movement clauses, and illustrates the overlapping characteristics of Copular sentences with both clause-types. ([+Wh] DP here only means that a DP A'-moves to Spec,CIP.)

	V-raising	Copular	Wh-movement
CIP-layer	V-to-CI	[+Wh] DP to Spec,CIP	[+Wh] DP to Spec,CIP
Lexical subject	left of CI	left of CI	below CI
Subject clitic	obligatory	obligatory	non-obligatory

Table 3: Syntactic characteristics of V-raising, Wh-raising, and Copular clauses

Support for the claim that the structure as in (41) involves A'-movement comes from the fact that predicate questions have the same form, as in (42). Here the *wh*-word occupies the position preceding *la*, as in any Wh-movement structure, but the clause-internal subject is a clitic, as in the declarative sentence in (41). Second, such clauses can be extracted out of long-distance, as in (43), which is in Wolof only possible in the presence of the A'-movement complementizer (Dunigan 1994; Martinović 2015a, 2017b).

- (42) Predicate question copular sentence
 Xale yi lan la=ñu?
 child the.PL what C_{Wh}=3PL
 “What are the children?”

- (43) Long-distance extraction from a predicational copular sentence
 Lan la Magat gëm ni xale yi t_i la=ñu?
 what C_{Wh} Magatte believe that child the.PL t_i C_{Wh}=3PL
 ‘What does Magatte believe the children are?’

I claimed in section 5 that the subject position is available in Wh-raising constructions due to Head-Splitting, resulting from the featural composition of C_{Wh} and the particular mechanism of feature checking. One task here is to explain why a copular sentence, also a Wh-raising construction, cannot have a non-clitic subject to the right of C, as in (44).

- (44) No clause-internal subject in copular sentences
 *Sàcc la xale yi.
 thief C_{Wh} child the.PL
 Intended: ‘The children are thieves.’

There are other types of copular sentences that look like the traditional V-raising and Wh-raising clauses. I do not discuss them here, nor the distribution of the different copular sentence types. My focus are the copular sentences presented above, with no copula, the nominal predicate in Spec,CIP, and an obligatory clause-internal subject clitic. I argue that these sentences are in fact regular Wh-raising structures, and that the clause-internal subject can only be a clitic due to ordering requirements placed on the predicational structure containing the two main constituents during Spell-out. The argument will proceed as follows.

First, I propose that the two nominal constituents in a copular sentence start out in an asymmetrical *small clause*. I adopt the analysis by Ko (2014) (that builds on Fox and Pesetsky 2005), who argues that small clauses are Spell-out domains wherein the order of the two constituents is fixed for the remainder of the derivation. Given that the predicate raises to Spec,CIP, a non-clitic subject can only surface in a mixed copular sentence if it is to the left of the predicate. Subject clitics, however, seem to be exempt from the ordering requirements imposed by linearization. I argue that this has to do with the ability of clitics to escape the small clause before linearization, given that they move via a special type of movement, different from either head movement, or A/A'-movement, that is not subject to the same restrictions. I also propose that the non-clitic subject can surface only if it is contained together with the clitic in a *big-DP*, as in V-raising sentences.

I continue this section by first discussing the properties of clitics and clitic movement, as this is the central part of the argument. I then spell out the analysis of copular sentences.

6.2 Wolof clitics

The main component of the analysis of copular sentences is explaining why these Wh-raising structures allow for only clitic subjects, even though they should contain a position for a clause-internal subject, as argued in section 5. In order to understand the argument that I will put forth, we need to take a closer look at the morphosyntax of Wolof clitics.

Clitics in Wolof commonly surface adjoined to the sister of the highest functional head in the clause (i.e. they linearly follow this head). In finite mono-clausal structures they cluster to the right of the sentence particle in a fixed order (SUBJ > OBJ > LOC), as in (45).

- (45) *Clitics cluster after CI in finite clauses*
 Ñoom jox-na=**ñu=ma=ko=fi**.
 3PL.STR hand-C_V=3PL=1SG.OBJ=3SG.OBJ=LOC
 'They handed it to me here.'

Positioning of pronominal clitics in a cluster immediately to the right of CI is reminiscent of 2nd position (Wackernagel) cliticization, and is obligatory in mono-clausal structures with a sentence particle. However, this position itself is not what licenses them, as not all clause-types in Wolof contain the CIP-layer, but can still contain clitics. One such clause type is what I call a *minimal clause*.²¹ Such a clause cannot contain any functional material (aspect, tense, negation),

²¹The presence of a sentence particle is obligatory in order for the sentence to contain temporal markers (Njie 1982), or negation (Zribi-Hertz and Diagne 2003). Clauses without sentence particles must be in a context in which they can acquire their temporal reference, or directly preceded by a temporal adverbial phrase. Minimal clauses are variously termed in the literature: propositions with zero aspect (Sauvageot 1965), minimal propositions (Church

but can appear as an independent structure. I follow Zribi-Hertz and Diagne (2002) and consider it to be the size of a *v*P. It is used in running narrative contexts, after temporal properties of the discourse have been established. In minimal clauses the subject clitic is preverbal, and the object clitic postverbal, as illustrated in (46).²² In this context, clitics look much more like phrasal constituents than like heads.

- (46) Clitics in minimal clauses
 Ñu=gis=ko.
 3PL=see=3SG.OBJ
 ‘They see him.’

It may seem that clitics in (46) are in situ, but double-object constructions show that this is not entirely the case. As in English, in Wolof double-object constructions the Goal must precede the Theme when the Goal is not a PP (Zribi-Hertz and Diagne 2002, 853). Double-object constructions in minimal clauses reveal that there is still clitic movement, even when there is no CI. In that case, the subject clitic, which is the highest, does not move anywhere, but if the Theme object (which otherwise must follow the Goal) is a clitic, it cannot stay in situ, but must move to be right-adjacent to the verb, over the Goal, as in (47) (example from Zribi-Hertz and Diagne 2002, 853). In that case, the clitics is ambiguous between a Theme and a Goal.

- (47) Object clitics in double-object constructions in minimal clauses
 Xale yi wan=ko Aram.
 child the.PL show=3SG.OBJ Aram
 (i) ‘The children show Aram to him/her’
 (ii) ‘The children show him/her/it to Aram.’

If the clause in (47) is a *v*P, as Zribi-Hertz and Diagne (2002) argue, with the verb in *v*, this means that the object clitic moves to end up right-adjacent to *v*. This suggests that clitics adjoin to the sister of the highest functional projection in a particular domain (this domain being at most a CIP).

Another important property of clitics is their ability to land in various positions along the clausal spine. Evidence for this comes from embedded non-finite clauses, which can sometimes contain what appears to be the infinitive marker *a*.

- (48) The infinitive marker
 Da-ma bëgg-a-toog ceebujën.
 do.C_V-1SG want-INF-cook ceebujen
 ‘I want to cook ceebujen.’

The infinitive marker seems to occur at the edge of the embedded non-finite complement.²³ Crucial

1981), narrative propositions (Dialo 1981; Robert 1991), or *f*-deficient propositions (Zribi-Hertz and Diagne 2003).

²²I translate minimal clauses in present tense, but as mentioned, their temporal properties are dependent on context.

²³Torrence (2012) considers it a non-finite complementizer, however, given that it does not block clitic climbing, it is probably a lower head, as Wolof clitics target C-positions, as Wackernagle clitics, and should therefore not climb

data come from cases in which the non-finite clause contains a clitic that climbs to the matrix clause. Interestingly, this clitic can pied-pipe with it the infinitive marker *a*, suggesting that the clitic made a stop at the edge of the non-finite clause. The infinitive marker can never climb on its own.²⁴

- (49) *Infinitive marker is pied-piped with the clitic*
 Roxaya daf-a=∅=**leen**=a jéem lekk.
 Roxaya do-C_v=3SG=3PL.OBJ=INF try eat
 ‘Roxaya tried to eat them.’

The precise mechanism of how the infinitive marker gets pied-piped with the clitic is not important for us at the moment. Example (49) is relevant because it shows that clitics make stops at various positions as they move to their final landing position. This property of clitics is what will allow us to understand why they can escape the ordering requirements imposed by linearization.

Clitics have been proposed to move via a special type of movement, distinct from head movement or A/A'-movement (Ouhalla 1989; Arregi and Nevins 2012). Given the fact that clitics in Wolof do not land in either a head or a specifier position, but that they follow a particular head in the clausal spine (i.e. they adjoin to the sister of that head), this is a reasonable assumption to also make for Wolof clitics. I propose that clitics move from their base position and adjoin to the sister of the next higher head as soon as that head is merged. I also assume Cyclic Spell-out (Uriagereka 1999), and crucially propose that clitics move out of a particular Spell-out domain *before* Spell-out, and keep moving along the clausal spine as new functional heads are merged. Movement of the clitics before Spell-out will be a crucial assumption that will allow us to explain obligatory clitic subjects in copular sentences. I discuss the details of Spell-out and how it is relevant for the issue in question in the next section.

Let us illustrate this proposal with a simple example. Consider the structure in (50). Assume that *v* triggers Spell-out of its complement, VP, which contains the object clitic *ko*. I propose that the VP is *marked for Spell-out* when *v* is merged, but that *ko* escapes it before Spell-out takes place, moving to a position where it adjoins to the sister of *v*. I label this position as an adjunct position (here, VP). The clitic therefore *tucks in* between the head and its complement, à la Richards (1997, 1999). Other syntactic movements can follow Clitic Movement, but the two operations are essentially independent of one another.

out of a CP (Müller 1996; Wurmbrand 2001).

²⁴Data from work by Danfeng Wu and Yadav Gowda on the infinitive in Wolof as part of a field methods course at MIT.

(50)

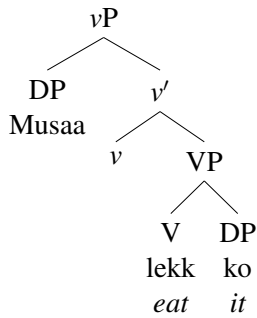

(51)

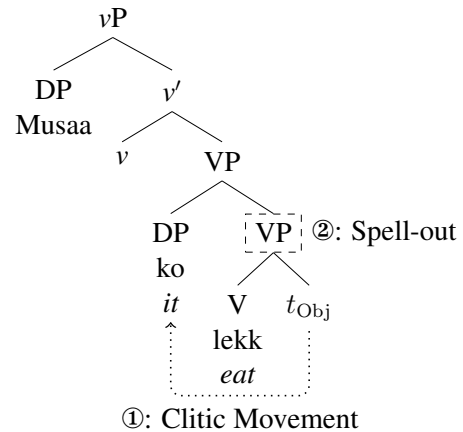

I follow Fox and Pesetsky (2005) in assuming that once a particular domain is spelled out (which in this context means *linearized*), the order of its constituents with respect to one another cannot be changed in higher domains, even though they can still move out of the spelled out domain.

I propose that Clitic Movement proceeds along the functional spine as illustrated above, moving to adjoin to each new functional head, before each subsequent domain is spelled out. Clitics will therefore not be linearized until the end of the derivation. In the following section, I demonstrate how this proposal allows us to explain that copular sentences can only contain clitic subjects.²⁵

6.3 The analysis

Our main task in this section is to explain why in copular sentences, which are A'-movement constructions, the clause-internal subject must be a clitic. I proposed in section 5 that A'-movement constructions contain a CI with the structure in (52).

(52) Feature geometry of CI in Wh-raising clauses
 [CI D* [CI Wh* [CI CI]]]

I also propose, following Bowers (1993); Svenonius (1994); Adger and Ramchand (2003); Mikkelsen (2005); den Dikken (2006), and others, that the two nominals in a copular sentence are contained inside an asymmetrical *small clause*, where the relationship between the two nominals is mediated by a functional head. Since in Wolof the predicate A'-moves to Spec,CIP, I endow it here with a

²⁵Anagnostopoulou (2003) discusses a phenomenon in Greek in which cliticization is obligatory in certain cases of DP movement; specifically, in double object constructions a lower nominative argument can move to Spec,TP over a higher argument only if the higher argument is a clitic (which in that case also moves to T). Anagnostopoulou relates this to locality – a DP cannot undergo A-movement over an intervening DP. Since we are dealing with A'-movement of a predicate over a subject in Wolof, it is difficult to invoke a violation of Locality. The analysis proposed here, however, might be extendible to the phenomenon in Greek. In any case, the observation that cliticization licenses another type of movement in both Greek and Wolof is worth noting.

[Wh⁺] feature.²⁶ The structure of this predicational clause is illustrated in (53).²⁷

(53)

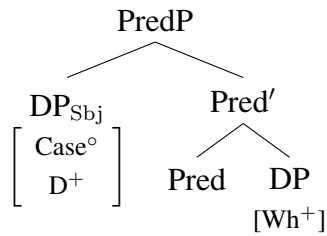

What we see in Wolof is that the subject in (53) cannot be a non-clitic DP. This is puzzling, as the derivation of the copular sentence in (54) should proceed in the same manner as the derivation of any *wh*-movement construction where the extracted element is a non-subject. The resulting structure should be as in (55).

(54) Xale yi sàcc la=ñu.
 child the.PL thief C_{Wh}=3PL
 “The children are thieves.”

(55)

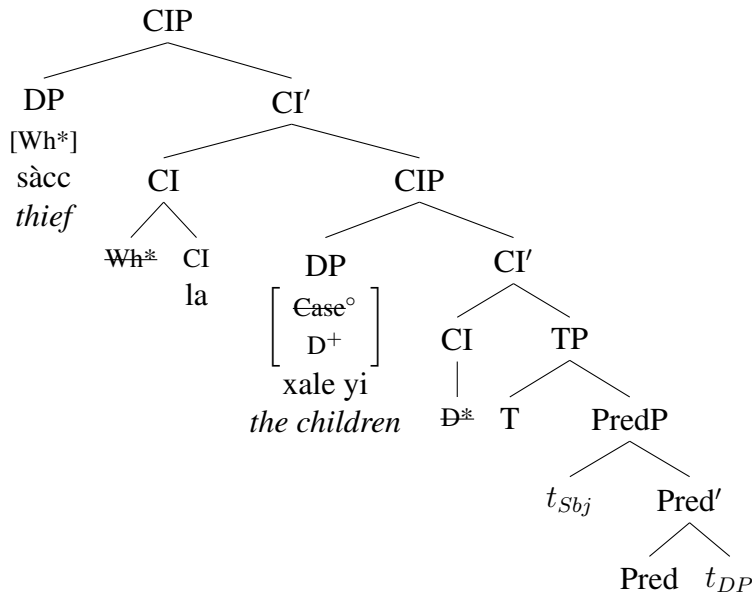

This, however, is not a grammatical predicational copular sentence in Wolof. The subject to the right of the sentence particle can only be a clitic, and a non-clitic subject can only appear to the left of the predicate. The explanation I offered for the same phenomenon in V-raising clauses is

²⁶I do not address the very interesting fact that there are essentially two options in Wolof finite clauses: either the verb raises to CI, or an XP A'-moves to Spec,CIP. The two operations being in complementary distribution has potentially interesting consequences for our understanding of the notions of *predication*, the relationship between head movement and A'-movement, and the nature of the features that trigger them. Some preliminary thoughts on how A'-movement is related to predication can be found in Klecha and Martinović 2015.

²⁷I ignore the Case° and D+ features on the predicate nominal.

the absence of a subject position below the sentence particle, as a result of an unsplit CI head. Wh-raising sentences, however, have a split CI head, and the splitting occurs due to the feature composition of CI and the proposed ordered feature-checking. The reason for the clause-internal subject being a clitic therefore cannot be the absence of a subject position to the right of the sentence particle.

I propose that the obligatoriness of a clitic subject in copular sentences is due to an order-preservation effect. I follow Ko (2014) who develops arguments for the model of Spell-out proposed in Fox and Pesetsky 2005, according to which cyclic effects in syntax are the result of Cyclic Linearization, a mapping procedure between the syntax and PF, which establishes relative orderings of syntactic elements inside a Spell-out domain. Nothing prohibits movement out of a spelled out domain, as long as the linear order established during Spell-out is maintained. The edge of a Spell-out domain does not directly play the role of an escape hatch in Fox & Pesetsky’s system, but if an element from inside the domain independently moves to the edge, then when it is spelled out it will precede all other syntactic elements in the domain and will be free to move to a higher domain. If, however, an element that moves to a higher domain results in ordering information that is not consistent with that stored in previous cycles, the derivation cannot be linearized at PF. Ko (2014) argues that small clauses, such as the PredP in a copular sentence, are Spell-out domains. Unlike larger predicational structures, such as *v*Ps, the predicate inside the PredP cannot move to the edge of PredP, illustrated in (56), as this would violate locality constraints on movement: the complement of a head should not move to its specifier.

(56) Anti-locality and predicate fronting

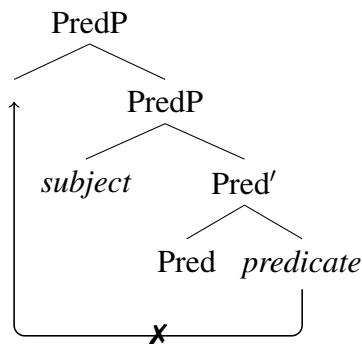

I have argued that clitics are special in that they can escape PredP before it is spelled out. The subject clitic therefore does not get linearized with respect to the predicate DP during the Spell-out of the PredP. If the subject in a copular clause is a clitic, no ordering conflict arises.

A non-clitic subject can occur to the left of the nominal predicate in copular sentences. In V-raising clauses, we saw that the subject position to the left of CI was a non-topic position, due to the fact that a subject in those sentences can be a bare quantifier (see (10)). I therefore proposed that in V-raising clauses the subject is in Spec,CIP. In Wh-raising clauses, however, another element already occupies Spec,CIP – the A’-moved phrase. The non-clitic subject can therefore not occupy Spec,CIP, but must be in a position to the left of it, and there is evidence that this is indeed so. In copular sentences, namely, a bare quantifier cannot be the subject:

(57) No bare quantifier subject in copular sentences

*Kenn_i sàcc la= \emptyset _i.

someone thief C_{Wh}=3SG

intended: 'Someone is a thief.'

Given the fact that bare quantifiers cannot be topics, it follows that the non-clitic subject in copular sentences is obligatorily left-dislocated to a topic position. I propose that, similar to the subject in V-raising structures, a non-clitic subject in copular sentences can only occur if it is part of a *big*-DP. One of the conditions placed on the *big*-DP is that the doubled argument not remain clause-internal. Such DPs are therefore always to the left of CI. In the case of copular sentences, the non-clitic DP can only be topicalized, as Spec,CIP is occupied by the predicate DP. Thus, only the derivation with subject topicalization converges. This structure also satisfies the ordering requirements placed by *Cyclic Linearization* on the small clause. The derivation of a clause with a *big*-DP subject is as follows. The structure of the predicational small clause is given in (58).

(58)

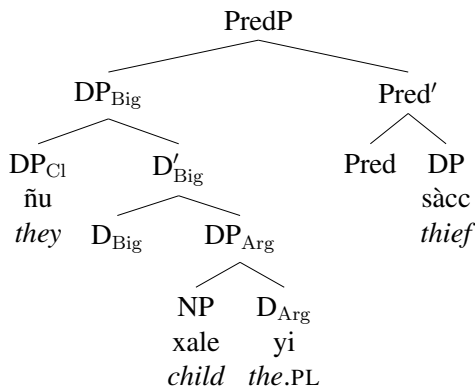

The first step is for the clitic to escape the PredP, by tucking in between the higher functional head and its complement. For simplicity, I skip all intervening heads between PredP and CI. Next, PredP is spelled out and the order of DP_{Arg} and the predicate DP is at this point fixed. CI then continues to check its features, the highest of which is D*. Given that the clitic does not participate in syntactic operations, it cannot be attracted to Spec,CIP. DP_{Arg} therefore moves to Spec,CIP to check D* on CI.

(59)

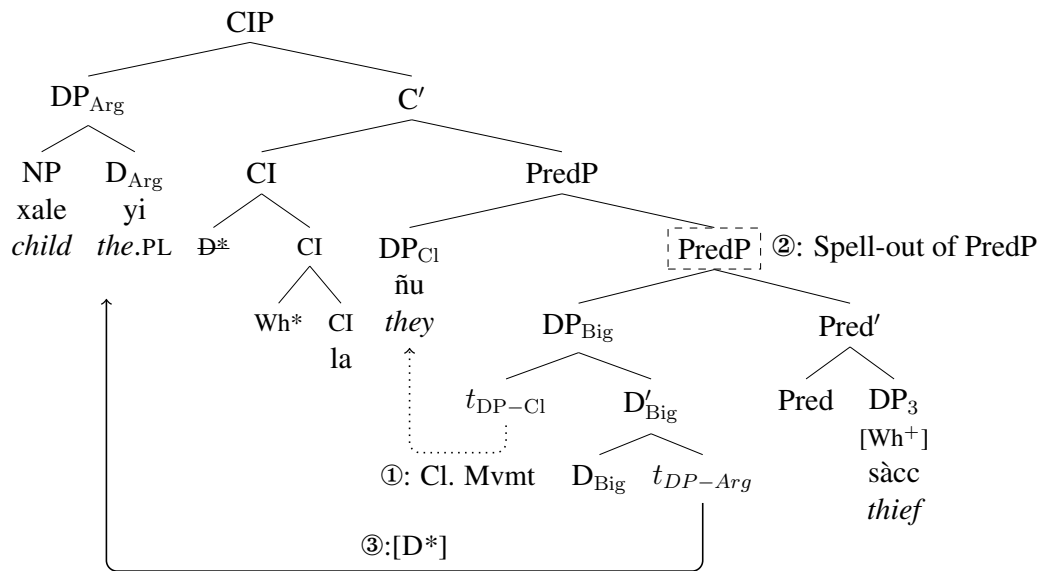

The rest of the derivation continues as in any A'-movement construction: CI splits, and the phrase carrying the *wh*-feature, the predicate DP, moves to Spec,CIP. Due to the requirement that the doubled argument not remain clause-internal together with the clitic, it topicalizes. The final structure is in (60). Note that after Head-Splitting the subject clitic moves to tuck in between the new CI head and its complement.

(60)

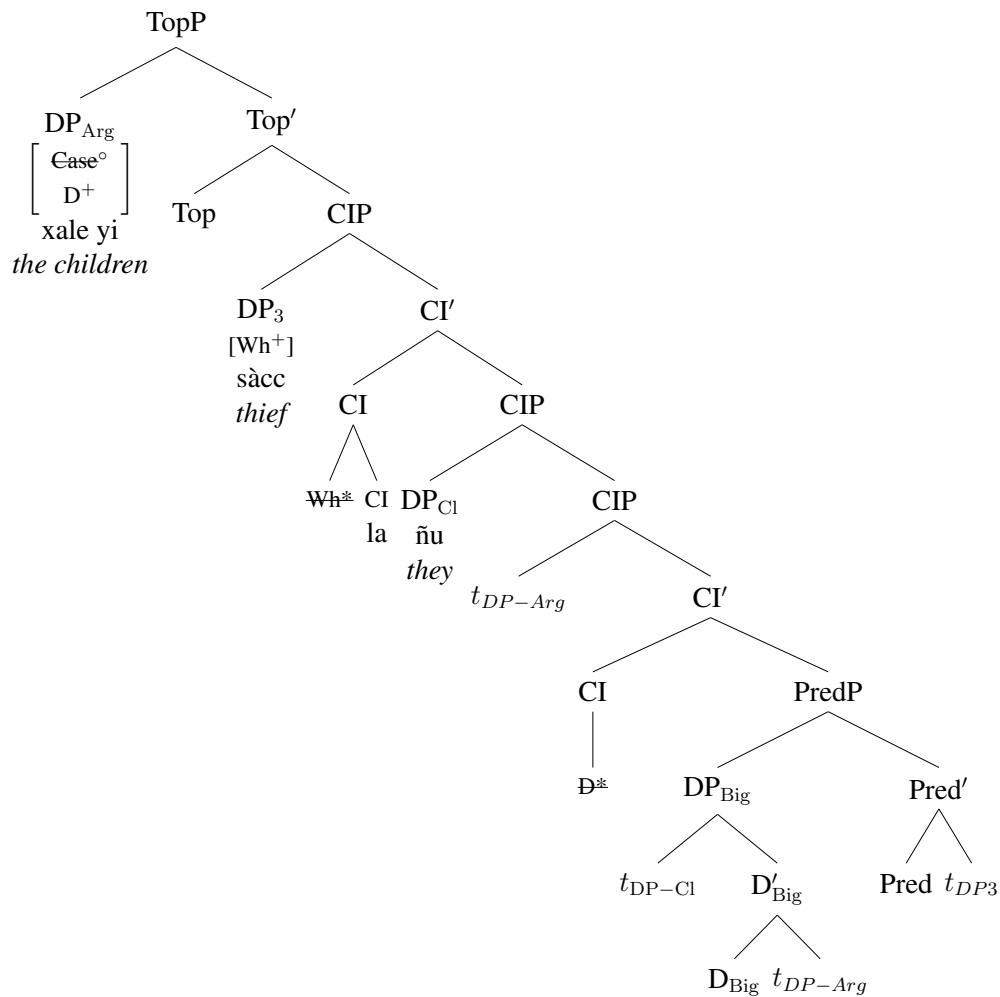

6.4 Summary

In this section I addressed data from copular sentences, which present a more complex picture of the interplay between the two featurally different types of CIs and the availability of a clause-internal subject position. I attributed the apparent absence of a subject position in copular clauses, which are *Wh*-movement constructions and should therefore have one, to an order preservation effect advocated in Fox and Pesetsky (2005) and Ko (2014). Order Preservation requires the order of constituents in a predicational domain, here specifically a small clause, established during Spell-out, to remain unchanged in the rest of the derivation. Given that the predicate DP in Wolof copular sentences *A'*-moves to the higher Spec,CIP, a subject in a lower Spec,CIP would cause a violation of Order Preservation. I proposed that clitics are exempt from such a requirement, given their unique type of movement, which takes them up the clausal spine in a stepwise fashion. I argued that this movement occurs before Spell-out of a particular domain. Given that the predicate nominal in copular sentences ends up in Spec,CIP, the only subject that can be lower than the predicate is a clitic. Any other subject nominal can only be in a left-dislocated position.

7 Conclusion

In this paper we investigated two Wolof clause-types that differ in the amount of structure over which features of C and T are distributed: they are either contained on one head, yielding non-cartographic effects, or spread over two heads, resulting in cartographic effects. I proposed a novel mechanism, Head-Splitting, which derives both clause-types, relying on the mechanism of strictly ordered feature-checking and cyclic partial head-reprojection. The proposal laid out here addresses the fundamental question of how a syntactic structure is built, and is as such highly relevant for one of the central questions resulting from the work on cartography – whether all functional elements are always present in the functional spine in all languages, or not. A strong version of the cartographic approach assumes that all functional heads are always in the structure, and cross-linguistic variation results from the presence or absence of Merge and/or Move and the overt or covert nature of functional heads and their specifiers. According to a weaker version of the cartographic approach, all functional projections are not necessarily always present in the functional structure, but if they do appear, they do so in a particular hierarchical order. Some proposals, such as the one laid out in Bobaljik and Thráinsson (1998), argue that the same features are in some languages spread over more functional heads, and in others bundled on fewer heads, as a point of parametric variation. My analysis takes a middle position, in that it assumes that the hierarchy of functional projections is transferred into a feature hierarchy inside a head, which may, via Head-Splitting, result in a hierarchy of projections. In other words, constructions that on the surface have less structure do have fewer projections, but the functional hierarchy may be preserved inside the head in the feature geometry. This work also adds a novel perspective to the long-standing discussion on the nature of the connection between C and T. It has long been noted that C and T are not completely independent of one another, but share a host of properties. This is often captured via selection, however, the overwhelming cross-linguistic evidence for this connection makes such an analysis, reserved for idiosyncratic behaviors, unattractive. Wolof data show that there are languages in which C and T appear to be separate heads in some structures, and one head in other structures, pointing to their unified origin. The analysis advocated in this work allows us to capture the C-T link in a new way. Finally, the analysis advocated here relates to the proposal that all features start on one head and are then spread over a larger amount of structure – the Feature Inheritance (FI) approach. In FI, all features that may trigger syntactic operations are initially located on phase heads, and present on other heads only by being passed down via some type of inheritance mechanism. One of the more obvious problems with FI is that the downward inheritance is at variance with strict cyclicity, in that it assumes that featureless heads are merged into the derivation, inherit features from a higher head, after it is merged, and then trigger syntactic operations which may lead to countercyclic Move or Merge. The present proposal in terms of partial head reprojection, on the other hand, is strictly cyclic and proceeds upward, offering an alternative to FI. This analysis has potential repercussions for a variety of phenomena resting on the observation that there is cross-linguistic variation in the correspondence between the number of functional features and heads, most notably in the verbal inflectional layer and the left periphery, and for phenomena in which a certain element is sometimes instantiated in one position, and other times in another, in one and the same language (e.g. affixation vs. periphrasis inside one paradigm; definiteness marking in DPs in Scandinavian, etc.).

References

- Abels, Klaus. 2012. Phases: An essay on cyclicity in syntax. Berlin: De Gruyter.
- Ackema, Peter, Ad Neeleman, and Fred Weerman. 1993. Deriving functional projections. In Proceedings of the 23rd Annual Meeting of the Northeast Linguistic Society, 17–31. Amherst: GSLA.
- Adger, David, and Gillian Ramchand. 2003. Predication and equation. Linguistic Inquiry 34:325–359.
- Anagnostopoulou, Elena. 2003. The syntax of ditransitives: Evidence from clitics. Berlin: Mouton de Gruyter.
- Anagnostopoulou, Elena, Henk van Riemsdijk, and Frans Zwarts, ed. 1997. Materials on left dislocation. Amsterdam: John Benjamins.
- Arregi, Karlos, and Andrew Nevins. 2012. Morphotactics. Basque Auxiliaries and the Structure of Spellout. Dordrecht: Springer.
- Baker, Mark. 1988. Incorporation. Chicago: University of Chicago Press.
- Baker, Mark. 2008. On the nature of the Antiagreement Effect: Evidence from wh-insitu in Ibibio. Linguistic Inquiry 39:615–632.
- Belletti, Adriana. 2005. Extended doubling at the VP periphery. Probus 17:1–35.
- Bhatt, Rajesh. 2002. The raising analysis of relative clauses: evidence from adjectival modification. Natural Language Semantics 10:43–90.
- Bjorkman, Bronwyn. 2011. BE-ing default: the morphosyntax of auxiliaries. Doctoral Dissertation, MIT, Cambridge, MA.
- Bjorkman, Bronwyn, and Hedde Zeijlstra. 2014. Upward Agree is superior. Ms., Toronto, ON & Göttingen: University of Toronto & Georg-August-Universität Göttingen. URL: <<http://ling.auf.net/lingbuzz/002350>>.
- Bjorkman, Bronwyn, and Hedde Zeijlstra. 2015. Upward Agree is superior. Presented at the 33rd West Coast Conference on Formal Linguistics (WCCFL 33). URL: <<http://individual.utoronto.ca/bjorkman/talks.html>>.
- Bjorkman, Bronwyn, and Hedde Zeijlstra. 2019. Checking up on (φ -)Agree. Linguistic Inquiry 50:527–569.
- Bobaljik, Jonathan David. 2002. A-chains at the PF-interface: Copies and "covert" movement. Natural Language and Linguistic Theory 20:197–267.
- Bobaljik, Jonathan David, and Höskuldur Thráinsson. 1998. Two heads aren't always better than one. Syntax 1:37–71.

- Bošković, Željko. 2002. A-movement and the EPP. *Syntax* 5:167–218.
- Bowers, John. 1993. The syntax of predication. *Linguistic Inquiry* 24:591–656.
- Cardinaletti, Anna, and Michal Starke. 1999. The typology of structural deficiency: A case study of three classes of pronouns. In *Clitics in the languages of Europe*, ed. Henk van Riemsdijk, 145–233. Berlin: Mouton.
- Carstens, Vicki. To appear. Delayed Valuation: a reanalysis of ‘upwards’ complementizer agreement and the mechanics of case. *Syntax* .
- Cecchetto, Carlo. 2000. Doubling structures and reconstruction. *Probus* 12:93–126.
- Chomsky, Noam. 1982. Some concepts and consequences of the Theory of Government and Binding. Cambridge, Mass: MIT Press.
- Chomsky, Noam. 1986. Barriers. MIT Press.
- Chomsky, Noam. 1995. The Minimalist Program. Cambridge, MA: MIT Press.
- Chomsky, Noam. 2000. Minimalist inquiries: The framework. In Step by step: Essays on Minimalist syntax in honor of Howard Lasnik, ed. Roger Martin, David Michaels, and Juan Uriagereka, 89–155. Cambridge, Mass.: MIT Press.
- Chomsky, Noam. 2001. Derivation by phase. In Ken Hale: A Life in Language, ed. Michael Kenstowicz, 1–52. Cambridge, MA: MIT Press.
- Chomsky, Noam. 2005. On Phases. MIT.
- Chomsky, Noam. 2008. On Phases. In Foundational Issues in Linguistic Theory: Essays in Honor of Jean-Roger Vergnaud, ed. Robert Freidin, Carlos P. Otero, and Maria Luisa Zubizarreta, 133–166. Cambridge, Mass: MIT Press.
- Chung, Sandra. 1998. The Design of Agreement: Evidence from Chamorro. Chicago and London: The University of Chicago Press.
- Church, Eric. 1981. Le système verbal du wolof. Université de Dakar, Documents Linguistiques.
- Cinque, Guglielmo. 1999. Adverbs and functional heads: A cross-linguistics perspective. Oxford: Oxford University Press.
- Cinque, Guglielmo. 2006. Restructuring and Functional Heads. The Cartography of Syntactic Structures, volume 4. New York: Oxford University Press.
- van Craenenbroeck, Jeroen, and Marjo van Koppen. 2008. Pronominal doubling in Dutch dialects: Big DPs and coordinations. In Microvariation in syntactic doubling, ed. Sjeff Barbiers, Olaf Koenenman, Marika Lekakou, and Margreet van der Ham, 207–249. Bingley: Emerald.
- Den Besten, Hans. 1989. Studies in West-Germanic syntax. Doctoral Dissertation, Katholieke Universiteit Brabant, Tilburg. [Distributed by: Rodopi, Amsterdam/Atlanta.].

- den Dikken, Marcel. 1995. Binding, expletives and levels. Linguistic Inquiry 26:347–354.
- den Dikken, Marcel. 2006. The syntax of predication, predicate inversion, and copulas. Cambridge, MA: MIT Press.
- Dialo, Amadou. 1981. Structures verbales du wolof contemporain. Dakar: Centre de Linguistique Appliquée de Dakar.
- Dunigan, Melynda B. 1994. On the clausal structure of Wolof. Doctoral Dissertation, University of North Carolina at Chapel Hill, Chapel Hill, NC.
- Erlewine, Michael Yoshitaka. 2018. Extraction and licensing in Toba Batak. Language 94:662–697.
- Fanselow, Gisbert. 2003. Münchhausen-Style Head Movement and the Analysis of Verb-Second. In Head Movement and Syntactic Theory, ed. Anoop Mahajan, 40–76. Los Angeles and Potsdam: UCLA & Universität Potsdam Working Papers in Linguistics. Vol. 3 of *Syntax at Sunset*.
- Fortuny, Jordi. 2008. The emergence of order in syntax. Amsterdam/Philadelphia: John Benjamins.
- Fox, Danny, and David Pesetsky. 2005. Cyclic linearization and syntactic structure. Theoretical Linguistics 31:1–45.
- Franks, Steven, and Catherine Rudin. 2005. Bulgarian clitics as K^0 heads. In Formal approaches to Slavic linguistics 13: The South Carolina meeting 2004, ed. Steven Franks, Frank Y. Gladney, and Mila Tasseva-Kurktchieva, 106–118. Ann Arbor, MI: Michigan Slavic Publications.
- Gallego, Ángel J. 2014. Deriving Feature Inheritance from the Copy Theory of Movement. The Linguistic Review 34:41–71. DOI: 10.1515/tlr-2013-0021.
- Gallego, Ángel J. 2017. Remark on the EPP in labeling theory: Evidence from Romance. Syntax 20:384–99. DOI: 10.1111/synt.12139.
- Georgi, Doreen, and Gereon Müller. 2007. Noun Phrase structure by Reprojection. Linguistische Arbeits Berichte 85:263–301. Universität Leipzig.
- Georgi, Doreen, and Gereon Müller. 2010. Noun-Phrase structure by Reprojection. Syntax 13:1–36.
- Giorgi, Alessandra, and Fabio Pianesi. 1996. Tense and aspect: From semantics to morphosyntax. Oxford: Oxford University Press.
- Grohmann, Kleanthes, John Drury, and Juan Castillo. 2000. No more EPP. In Proceedings of the 19th Annual Meeting of the West Coast Conference on Formal Linguistics, ed. Roger Billery and Brook Danielle Lillehaugen, 153–166. Somerville, Mass: Cascadilla Press.
- Haider, Hubert. 2000. Branching and Discharge. In Lexical specification and insertion, ed. Peter Culicover Coopmans, Martin Everaert, and Jane Grimshaw, 135–164. Amsterdam: Benjamins.

- Haider, Hubert. 2005. How to turn German into Icelandic – and derive the OV/VO contrast. Journal of Comparative Germanic Linguistics 8:1–53.
- Harley, Heidi. 2017. The 'bundling' hypothesis and the disparate functions of little *v*. In The verbal domain, ed. Roberta D'Alessandro, Irene Franco, and Ángel J. Gallego, 3–28. Oxford: Oxford University Press.
- Harley, Heidi, and Elizabeth Ritter. 2002. Person and number in pronouns: A feature-geometric analysis. Language 78:482–526.
- Holmberg, Anders. 2000. Scandinavian stylistic fronting: How any category can become an expletive. Linguistic Inquiry 31:445–483.
- Hornstein, Norbert, and Juan Uriagereka. 2002. Reprojections. In Derivation and Explanation in the Minimalist Program, ed. Samuel David Epstein and T. Daniel Seely, 106–132. London: Blackwell.
- Klecha, Peter, and Martina Martinović. 2015. Exhaustivity, predication and the semantics of movement. In Proceedings of the 41st Annual Meeting of the Berkeley Linguistic Society. [Http://dx.doi.org/10.20354/B4414110005](http://dx.doi.org/10.20354/B4414110005) Retrieved from <https://escholarship.org/uc/item/8gn9b6q8>.
- Ko, Heejeong. 2014. Edges in Syntax. scrambling and Cyclic Linearization. New York: Oxford University Press.
- Koenenman, Olaf. 2000. The flexible nature of verb movement. Doctoral Dissertation, Utrecht University.
- Koopman, Hilda. 1996. The Spec Head configuration. In Syntax at Sunset, UCLA Working papers in syntax and semantics, ed. Edward Garrett and Felicia Lee.
- Koopman, Hilda. 2005. Agreement: in defence of the "Spec head configuration". In Agreement systems, ed. Cedric Boeckx. Benjamins.
- Landau, Idan. 2007. EPP Extensions. Linguistic Inquiry 38:485–523.
- Legate, Julie Anne. 2008. Morphological and Abstract Case. Linguistic Inquiry 39:55–101.
- Legate, Julie Anne. 2011. Under-Inheritance. Paper presented at North East Linguistic Society (NELS) 42, University of Toronto.
- Manetta, Emily Walker. 2006. Peripheries in Kashmiri and Hindi-Urdu. Doctoral Dissertation, University of California, Santa Cruz, Santa Cruz, CA.
- Manetta, Emily Walker. 2011. Peripheries in Kashmiri and Hindi-Urdu: The syntax of discourse-driven movement. Amsterdam/Philadelphia: John Benjamins.
- Mangold, Max. 1977. Wolof pronoun verb patterns and paradigms., volume *Forschungen zur Anthropologie und Religionsgeschichte* 3. Saarbrücken: Homo et Religio.

- Martinović, Martina. 2013. The topic-comment structure in copular sentences: Evidence from Wolof. In Proceedings of the 39th Annual Meeting of the Berkeley Linguistic Society, 137–151. The Linguistic Society of America. DOI: <http://dx.doi.org/10.3765/bls.v39i1.3875>.
- Martinović, Martina. 2015a. Feature geometry and head-splitting: Evidence from the morphosyntax of the Wolof clausal periphery. Doctoral Dissertation, University of Chicago, Chicago, IL.
- Martinović, Martina. 2015b. Information structure of copular sentences in Wolof. In Selected Proceedings of the 44th Annual Conference on African Linguistics, ed. Ruth Kramer, Elizabeth C. Zsiga, and One Tlale Boyer, 165–179. Somerville, MA: Cascadilla Proceedings Project.
- Martinović, Martina. 2017a. Head-Splitting at the Wolof clausal periphery. In Proceedings of the 34th West Coast Conference on Formal Linguistics, ed. Aaron Kaplan, Abby Kaplan, Miranda K. McCarvel, and Edward J. Rubin, 364–371. Somerville, MA: Cascadilla Proceedings Project.
- Martinović, Martina. 2017b. Wolof *wh*-movement at the syntax-morphology interface. Natural Language and Linguistic Theory 35:205–256. DOI: 10.1007/s11049-016-9335-y.
- Martinović, Martina. 2019. Interleaving syntax and postsyntax. Spell-out before syntactic movement. Syntax .
- Martinović, Martina, and Marie-Luise Schwarzer. 2018. Locatives and biclausal progressives in Wolof. In Proceedings of the 48th Annual Meeting of the North East Linguistic Society.
- Matushansky, Ora. 2006. Head movement in linguistic theory. Linguistic Inquiry 37:69–109.
- Merchant, Jason. 2006. Polyvalent case, geometric hierarchies, and split ergativity. In Proceedings of the 42nd Annual Meeting of the Chicago Linguistic Society, ed. Jackie Bunting, Sapna Desai, Robert Peachey, Chris Straughn, and Zuzana Tomkova, volume 2, 47–67. Chicago, IL: Chicago Linguistic Society.
- Merchant, Jason. 2011. Aleut case matters. In Pragmatics and Autolexical Grammar: In honor of Jerry Sadock, ed. Etsuyo Yuasa, Tista Bagchi, and Katharine P. Beals, chapter 382–411. Amsterdam: John Benjamins.
- Mikkelsen, Line. 2005. Copular clauses: specification, predication and equation. Amsterdam: John Benjamins Publishing Company.
- Müller, Gereon. 1996. A constraint on remnant movement. Natural Language and Linguistic Theory 14:355–407.
- Müller, Gereon. 2010. On deriving CED effects from the PIC. Linguistic Inquiry 41:35–82.
- Njie, Codu Mbassy. 1982. Description syntaxique du wolof de Gambie. Dakar, Senegal: Les Nouvelles Editions Africaines.
- Ouali, Hamid. 2008. On C-to-T phi-feature transfer: The nature of agreement and anti-agreement in Berber. In Agreement restrictions, ed. Roberta D'Alessandro, Susann Fischer, and Gunnar Hrafn Hrafnbjargarson, 159–180. Berlin: Mouton de Gruyter.

- Ouhalla, Jamal. 1989. Clitic Movement and the ECP: Evidence from Berber and Romance Languages. Lingua 79:165–215.
- Pesetsky, David. 1985. Morphology and Logical Form. Linguistic Inquiry 16:193–246.
- Pesetsky, David, and Esther Torrego. 2001. T-to-C movement: causes and consequences. In Ken Hale: A life in language, ed. Michael Kenstowicz, 355–426. Cambridge, MA: MIT Press.
- Pesetsky, David, and Esther Torrego. 2007. The Syntax of Valuation and the Interpretability of Features. In Phrasal and Clausal Architecture: Syntactic Derivation and Interpretation, ed. S. Karimi, V. Samiiian, and W. Wilkins. Benjamins.
- Platzack, Christer, and Anders Holmberg. 1995. The role of inflection in Scandinavian syntax. Oxford Studies in Comparative Syntax. New York/Oxford: Oxford University Press.
- Polinsky, Maria, and Eric Potsdam. 2001. Long-distance agreement and topic in Tsez. Natural Language and Linguistic Theory 19:583–646.
- Polinsky, Maria, and Omer Preminger. To appear. The *agreement theta generalization*. Glossa .
- Preminger, Omer. 2013. That’s not how you agree: a reply to Zeijlstra. The Linguistic Review 30:491–500.
- Pylkkänen, Liina. 2002. Introducing arguments. Doctoral Dissertation, MIT, Cambridge, Mass.
- Pylkkänen, Liina. 2008. Introducing arguments. Cambridge, MA: MIT Press.
- Richards, Marc. 2007. On feature inheritance: An argument from the phase impenetrability condition. Linguistic Inquiry 38:563–572.
- Richards, Marc. 2011. Deriving the edge: what’s in a phase? Syntax 14:74–95.
- Richards, Norvin. 1997. What moves where in which language. Doctoral Dissertation, MIT, Cambridge, MA.
- Richards, Norvin. 1999. Featural cyclicity and the ordering of multiple specifiers. In Working Minimalism, ed. Samuel David Epstein and Norbert Hornstein, 127–158. Cambridge: MIT Press.
- Rizzi, Luigi. 1986. On the status of subject clitics in Romance. In Studies in Romance Linguistics, ed. Osvaldo Jaeggli and Carmen Silva-Corvalan, 391–419. Dordrecht: Foris Publications.
- Rizzi, Luigi. 1997. The fine structure of the left periphery. In Elements of Grammar: handbook in generative syntax, ed. Liliane Haegeman, 281–337. Dordrecht/Boston: Kluwer Academic Publishers.
- Rizzi, Luigi. 2002. Locality and Left Periphery. In Structures and beyond., volume 3 of The Cartography of Syntactic Structures. Oxford University Press.
- Rizzi, Luigi, ed. 2004. The Structure of CP and IP. The Cartography of Syntactic Structures. New York: Oxford University Press.

- Rizzi, Luigi, and Ian Roberts. 1989/1996. Complex inversion in French. *Probus* 1: 1-30. Reprinted in A. Belletti and L. Rizzi, eds., *Parameters and Functional Heads*, pp. 63-90. Oxford University Press, Oxford, 1996.
- Robert, Stéphane. 1991. Approche énonciative du système verbal: le cas du wolof. Paria: Éditions du Centre National de la Recherche Scientifique.
- Rothstein, Susan. 1983. The syntactic forms of predication. Doctoral Dissertation, MIT, Cambridge, Mass.
- Russell, Margaret A. 2006. The syntax and placement of Wolof clitics. Doctoral Dissertation, University of Illinois at Urbana-Champaign, Urbana, IL.
- Sauvageot, Serge. 1965. Description synchronique d'un dialecte wolof: le parler du dyolof. Dakar: IFAN.
- Senghor, Leopold. 1963. La dialectique du nom et du verbe. In Wolof et sérère, Etudes de phonétique et de grammaire descriptive, ed. Gabriel Manessy and Serge Sauvageot. Université de Dakar, Publications de la Section de Langues et Littératures.
- Surányi, Balázs. 2005. Head movement and reprojection. In Annales Universitatis Scientiarum Budapestinensis de Rolando Eötvös Nominatae. Section Linguistica., ELTE Tomus XXVI, 313–342.
- Svenonius, Peter. 1994. Dependent nexus: Subordinate predication structures in English and the Scandinavian languages. Doctoral Dissertation, University of California, Santa Cruz, Santa Cruz, CA.
- Torrence, Harold. 2003. Verb movement in Wolof. UCLA Working Papers in Linguistics 9.
- Torrence, Harold. 2005. On the distribution of complementizers in Wolof. Doctoral Dissertation, University of California, Los Angeles, Los Angeles, CA.
- Torrence, Harold. 2012. The clause structure of Wolof: insights into the left periphery. Amsterdam/Philadelphia: John Benjamins Publishing.
- Uriagereka, Juan. 1995. Aspects of the syntax of clitic placement in Western Romance. Linguistic Inquiry 26:79–123.
- Uriagereka, Juan. 1999. Multiple Spell Out. In Working Minimalism, ed. Samuel David Epstein and Norbert Hornstein, 251–282. Cambridge, MA: MIT Press.
- Wurmbrand, Susanne. 2001. Infinitives: Restructuring and clause structure. Studies in Generative Grammar 55. Berlin: Mouton de Gruyter.
- Wurmbrand, Susi. 2012a. Parasitic participles in Germanic: Evidence for the theory of verb clusters. Taal en Tongval 64:129–156.

- Wurmbrand, Susi. 2012b. The syntax of valuation in auxiliary-participle constructions. In Coyote Working Papers: Proceedings of the 29th West Coast Conference on Formal Linguistics, ed. Jaehoon Choi et al. Tuscon: University of Arizona.
- Wurmbrand, Susi. 2014. The Merge Condition: A syntactic approach to selection. In Minimalism and Beyond: Radicalizing the interfaces, ed. P. Kosta, L. Schürcks, S. Franks, and T. Radev-Bork, 139–177. Amsterdam: John Benjamins.
- Zeijlstra, Hedde. 2012. There is only one way to agree. The Linguistic Review 29:491–539.
- Zribi-Hertz, Anne, and Lamine Diagne. 2002. Clitic placement after syntax: Evidence from Wolof person and locative markers. Natural Language and Linguistic Theory 20:823–884.
- Zribi-Hertz, Anne, and Lamine Diagne. 2003. Deficiences flexionnelles et temps totopiques en wolof. In Typologie des langues d’Afrique et universaux de la grammaire, vol. 2: benue-kwa, soninke, wolof, 205–231. Paris: Presses Universitaires de Vincennes/Éditions de l’Harmattan.