

Labeling and Scrambling in Japanese*

Nobu Goto

1 Introduction

In this paper, I would like to support Chomsky's (2012) labeling algorithm through careful examination of Japanese {XP, YP} structures created by scrambling. In particular, I propose that the ban on long-distance scrambling to a sentence-medial position in Japanese, as exemplified in (1), is explained as a case of unlabelable {XP, YP} structures that are ruled out at the interfaces (Chomsky 2012, Epstein, Kitahara, and Seely in prep., Fukui and Narita forthcoming, Moro 2000, Narita 2012, to appear, Ott 2012, Rizzi 2012 among others):

(1) (based on Saito (1985: 267))

- a. Taroo-ga minna-ni [_{CP} Hanako-ga sonohon-o mottei-ru to]
Taroo-nom all-to Hanako-nom that book-acc have-pres that
it-ta.
say-past
'Taroo said to all [that Hanako has that book]'

* Portions of this paper have been presented at the 34th Mie University Linguistic Colloquium (May 16, 2012) and at the 145th annual meeting of the Japanese Linguistic Society of Japan at Kyusyu University (November 24, 2012). I would like to thank the audience and in particular, Jun Abe, Tomohiro Fujii, Naoki Fukui, Takaomi Kato, Hisatsugu Kitahara, Taichi Nakamura, Hiroki Narita, Miki Obata, Koichi Otaki, Koji Sugisaki, Takumi Tagawa, and Kensuke Takita for their valuable suggestions and comments.

b. *sonohon-o_i Taroo-ga minna-ni* [_{CP} *Hanako-ga t_i mottei-ru to*]
 that book-acc Taroo-nom all-to Hanako-nom have-pres that
 it-ta.

say-past

‘(lit.) That book_i, Taroo said to all [that Hanako has t_i]’

c.??*Taroo-ga sonohon-o_i minna-ni* [_{CP} *Hanako-ga t_i mottei-ru to*]
 Taroo-nom that book-acc all-to Hanako-nom have-pres that
 it-ta

say-past

‘(lit.) Taroo, that book_i, said to all [that Hanako has t_i]’

(1b) is derived from (1a) via long-distance scrambling of the embedded object to the sentence-initial position. Saito (1985) observes that the sentence becomes marginal if a phrase that has undergone long-distance scrambling to a sentence-medial position, as in (1c).

This property of scrambling has long resisted a satisfactory explanation. In this paper, I argue that the marginality of (1c) is attributed to the fact that the intermediate step is of the form of {XP, YP}, yielding an unlabelable {XP, YP} structure that cannot be interpreted at the interfaces.

This paper is organized as follows: Section 2 briefly summarizes Chomsky’s (2012) Merge-based system with labeling adopted in this paper. Section 3 provides an explanation for the above paradigm in terms of labeling. Section 4 discusses some *prima facie* counterexamples to the proposed analysis. Section 5 concludes the paper.

2 The Logic of Labeling Algorithm

2.1 Chomsky (2012)

To ensure the discrete infinity of human language, Chomsky (1995, 2000, 2001, 2004, 2005, 2007, 2008, 2012) has assumed recursive Merge as a primitive operation. Merge is an elementary operation that combines two syntactic objects (SOs) into a set:

$$(2) \text{ Merge}(X, Y) = \{X, Y\}$$

In (2), if neither X nor Y is part of the other, it is called External Merge (EM), and if either X or Y is part of the other, it is called Internal Merge (IM). Outputs of Merge are simply sets with no label or order. Thus an immediate question raised by the simplest Merge-based system is: How can SOs be labeled or ordered?

As for the labeling problem, Chomsky (2012) assumes that in terms of what he calls the general principle that all SOs that reach the interfaces must be labeled, a label is required for interpretation at the interfaces,¹ and for SOs to be labeled, there is a fixed labeling algorithm (LA) that licenses SOs so that they can be interpreted at the interfaces, operating at the phase level along with other operations. Chomsky argues that LA is just minimal search as in Agree and the relevant information about SO is provided by a single designated element within it: a lexical item LI, a head. Thus, given $SO = \{H, XP\}$, H a head and XP not a

¹ Chomsky (2012) assumes that labels are necessary for interpretation at the interfaces, and Chomsky (2007, 2008) assumes that labels are necessary for further computations in narrow syntax. While a clear understanding of why and for what reasons they are necessary are still pending, I will here assume that labels are necessary both for further computations in narrow syntax and for interpretation at the interfaces.

head, the label of the SO is the label of H, because H is a single designated element within it; LA can unambiguously select it as the label of the SO:

$$(3) \text{ LA}(\{H, \text{XP}\}) = H$$

As noted in Chomsky (2008: 160, note 34), one potential problem with LA is that it cannot determine a label of $\text{SO} = \{\text{XP}, \text{YP}\}$:

$$(4) \text{ LA}(\{\text{XP}, \text{YP}\}) = ?$$

Here, neither is a head, and minimal search is ambiguous, so the label of the SO is not determined.

Then Chomsky (2012) proposes two ways in which the SO can be labeled:

(5) (A) $\{\text{XP}, \text{YP}\}$ can be labeled by raising either XP or YP so that there is only one visible head.

(B) $\{\text{XP}, \text{YP}\}$ can be labeled by sharing prominent features of XP and YP.

Under (A), therefore, the relevant SO is labeled as follows:

$$(6) \text{ a. } \text{XP}_i \dots \{t_i, \text{YP}\}$$

$$\text{ b. } \text{ LA}(\{t_i, \text{YP}\}) = \text{YP}$$

If, say, XP undergoes IM, as in (6a), then only YP becomes visible to LA; hence

the SO is labeled YP as in (6b).² Under (B), on the other hand, the SO is labeled as follows:

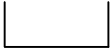
- (7) a. $\{XP_{[F]i}, YP_{[F]i}\}$

- b. $LA(\{XP_{[F]i}, YP_{[F]i}\}) = F$

If XP and YP share a prominent feature F, as in (7a), LA can take that to be the label of the SO; hence the SO is labeled F as in (7b).

Chomsky (2012) suggests that (B) crucially operates on {XP, YP} structures in criterial positions (Rizzi 2006, 2012) giving rise to Q-feature-agreement and ϕ -feature-agreement, and (A) operates on {XP, YP} structures involving obligatory IM of one of XP or YP. (A)'s relevant constructions are schematically given in (8):

- (8) a. small clauses: $\{XP_i, BE \{t_i, YP\}\}$
 b. the predicate-internal subject construction: $\{SUBJ_i, T, \{t_i, vP\}\}$
 c. successive-cyclic *wh*-movement: $\{Wh_i, C, \{t_i, CP\}\}$
 d. ECM constructions: $\{ECM-SUBJ_i, ECM-V, \{t_i, TP\}\}$

Despite the fact that all these constructions fall into the same environment in that one of the elements obligatorily undergo IM, the obligatoriness has been attributed to different principles: IM of XP in (8a) has been attributed to

² In fact, two more stipulative steps are involved in obtaining the effect of visible head: (i) a label of $\{t_i, YP\}$ after IM of XP_i is identical with that of YP, and hence (ii) only Y, a label of YP, is identified as the only visible head as the label of the SO.

Dynamic Antisymmetry Principle (Moro 2000); IM of SUBJ in (8b) to Extended Projection Principle (Chomsky 1981); IMs of Wh and ECM-SUBJ in (8c)-(8d) to the Principle of Feature-Checking (Chomsky 1995).

Interestingly, however, Chomsky (2012) argues that these principles can be unified under the same account in terms of labeling: since an $\{XP, YP\}$ structure is unlabelable, one of XP or YP must raise, period.³

Chomsky's (2012) proposals about labeling are thus summarized as in (9):

(9) A label is required for interpretation at the interfaces and assigned by a minimal search algorithm LA applying to an SO at the phase level. A label of $\{H, XP\}$ is H, and a label of $\{XP, YP\}$ is determined through (A) or (B):

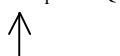
(A) a. $XP_i \dots \{t_i, YP\}$

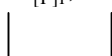
(B) a. $\{XP_{[F]i}, YP_{[F]i}\}$

b. $LA(\{t_i, YP\}) = YP$
 \approx successive-cyclic movement
 \approx other symmetric structures

b. $LA(\{XP_{[F]i}, YP_{[F]i}\}) = F$
 \approx criterial positions

In the following, I will show that LA properly functions in $\{XP, YP\}$ structures created by scrambling in Japanese as well, and lend further support to Chomsky's (2012) Merge-based system with labeling. Before that, though, I would like to present a less observed but very straightforward consequence of LA.

³ This analysis opens an interesting question of determinacy of IM: why XP must raise while YP does not, and vice versa. I leave the issue for future research.

2.2 A Consequence

As reviewed above, for {XP, YP} to be labeled and interpreted at the interfaces, one of XP or YP must raise, or both of XP and YP must agree. Obviously, this analysis of labeling allows us to have the following prediction:

(10) *A consequence of Chomsky's (2012) LA*

If neither IM nor Agree is applied to the SO, then {XP, YP} is ruled out at the interfaces because the SO is not labeled.

Goto (2012) argues that this prediction is indeed borne out, and claims that the Merge-over-Move Principle (MOM) proposed by Chomsky (1995, 2000) in explaining the following contrast can be attributed to the now familiar labeling problem:

- (11) a. There_i seems [*t*_i to_[EPP] be a man in the room]
b. *There seems [[a man]_i to_[EPP] be *t*_i in the room]

MOM holds that IM is computationally more costly than EM and syntax always applies EM whenever there arises a choice between EM and IM in the course of the derivation. The rationale behind MOM is that IM is composed of Agree and Merge, so it is more complex and more costly than EM (Chomsky 2000). Under MOM, therefore, the contrast between (11a) and (11b) is explained as follows: at the point where the infinitival clause [to_[EPP] be a man in the room] is constructed, the EPP of the infinitival T that requires its SPEC position to be filled by some overt phrase must be met. Here, there are two ways to satisfy the requirement:

either by externally merging the expletive *there* drawn from numeration, or by moving the associate *a man* from its base position. Which does syntax choose, then, EM of *there* or IM of *a man*? In terms of MOM, the answer is obvious: syntax chooses the EM of *there*, so the derivation of (11b) with the IM of *a man* is precluded.

The MOM-based account of (11b) is very straightforward, but it has been pointed out in the literature that it is problematic conceptually and empirically (see Sato 2008, Abe 2009, Narita to appear, Sorida 2012 among others). Conceptually, EM and IM are just instances of one and the same operation Merge, and hence there should not be any difference in computational cost between them. Also, MOM makes a wrong empirical prediction with regard to examples like the following; (12) is taken from Chomsky (2000) and (13) and (14) from Uriagereka (2008):

(12) There is a possibility [that [proofs]_i will be discovered *t_i*]

(13) a. (... and) the fact is [that there is a monk in the cloister]

b. (... and) there is the fact [that [a monk]_i is *t_i* in the cloister]

(14) a. A ball-room was [where there was a monk arrested]

b. There was a ball-room [where [a monk]_i was *t_i* arrested]

To accommodate these cases in MOM, Chomsky (2000) suggests that a numeration is segmented into a lexical subarray, corresponding to a derivational phase. However, Narita (to appear) and Sorida (2012) make strong arguments

against this approach, and reach the conclusion that the MOM-based account of (11b) ends in failure after all (see their original texts for relevant arguments).⁴

Thus, in response to this, Goto (2012) argues that the ungrammaticality of (11b) should be accounted for without recourse to MOM, and in fact, it should be attributed to the labeling problem. Specifically, he claims that at the point where the associate *a man* (DP) and the infinitival clause (TP) are merged, the form of unlabelable {XP, YP} structure is created:

(15) SO = {a man, to be in the room} (DP, TP)

Here, to label the SO for interpretation at the interfaces, one of *a man* or TP must raise, or both of *a man* and TP must agree. However, neither IM nor Agree is involved in the SO. Hence, the resulting structure is not labeled and ruled out at the interfaces without receiving interpretation:

(16) *{DP, TP}

In fact, since ϕ -features of the infinitival T are defective (Chomsky 2000), LA cannot find a label of the SO even if it asks for the help of Agree.

In this context, it is important to notice that the same problem does not arise in (12), (13b), and (14b), though they also have {DP, TP} structures at

⁴ Sato (2008) and Abe (2009) put forward a Move-approach to the expletive-construction, according to which the expletive (XP_{EXP}) forms a constituent with its associate (YP_{ASS}) underlyingly, and then XP_{EXP} is obligatorily raised to surface subject position – SPEC-T: XP_{EXPi} ... {t_i, YP_{ASS}} (cf. also Hornstein 2009). It might be reasonable to reinterpret the obligatory raising of XP_{EXP} in terms of labeling. I leave the exploration of this possibility for future research.

their intermediate positions. This is reasonable, however, in the situation where the T heads involved in these constructions are finite with complete ϕ -features: DP and TP share prominent features, namely ϕ -features, hence LA can take those to be the label of the SO:

$$(17) \text{LA}(\{\text{DP}_\phi, \text{TP}_\phi\}) = \phi$$

In this way, the ungrammaticality of (11b) can be explained as a case of unlabeled $\{\text{XP}, \text{YP}\}$ structures, and the problematic examples for MOM, (12)-(14), follow naturally from the systematic availability of Agree at intermediate positions. With LA, therefore, MOM is entirely eliminated in favor of the simplest Merge-based system. This will be a step forward to develop the minimalist program that seeks much simpler system.^{5, 6}

3 Proposals and Analysis

3.1 Unlabelable $\{\text{XP}, \text{YP}\}$ Structures in Japanese

In this section, I demonstrate that basically the same reasoning can apply to the relevant examples in Japanese, and more specifically, that the ban on long-distance scrambling to a sentence-medial position, repeated here as (18c), can be explained as an instance of unlabelable $\{\text{XP}, \text{YP}\}$ structures:

(18) (based on Saito (1985: 267))

⁵ See Epstein, Kitahara and Seely (in prep.) for the same approach to the MOM paradigm.

⁶ Under Chomsky's (2012) Merge-based system with labeling, Goto (2012) further argues that a condition on Merge proposed by Saito (2003) to explain effects of Proper Binding Condition (PBC) in Japanese can also be eliminated in favor of unconstrained Merge.

- a. Taroo-ga minna-ni [_{CP} Hanako-ga sono hon-o mottei-ru to]
 Taroo-nom all-to Hanako-nom that book-acc have-pres that
 it-ta.
 say-past
 ‘Taroo said to all [that Hanako has that book]’
- b. sono hon-o_i Taroo-ga minna-ni [_{CP} Hanako-ga *t_i* mottei-ru to]
 that book-acc Taroo-nom all-to Hanako-nom have-pres that
 it-ta.
 say-past
 ‘(lit.) That book_i, Taroo said to all [that Hanako has *t_i*]’
- c.??Taroo-ga ***sono hon-o_i*** minna-ni [_{CP} Hanako-ga *t_i* mottei-ru to]
 Taroo-nom that book-acc all-to Hanako-nom have-pres that
 it-ta
 say-past
 ‘(lit.) Taroo, that book_i, said to all [that Hanako has *t_i*]’

That is, the marginality of (18c) can be explained as follows: at the point where the embedded object *sono hon-o* ‘that book’ undergoes long-distance scrambling to the sentence-medial position, the form of SO = {XP, YP} is constructed:

(19) SO = {sono hon-o, minna-ni ...}

Here, neither IM nor Agree applies; hence LA is not invoked for labeling. As a result, the SO is not labeled and ruled out at the interfaces without receiving interpretation:

(20) *SO = {sono hon-o, minna-ni ...}

To be more precise, let us consider the following schematic derivation of (18c) (SUBJ = *Taroo-ga*; OBJ = *sono hon-o* ‘that book’; the box = Transfer):

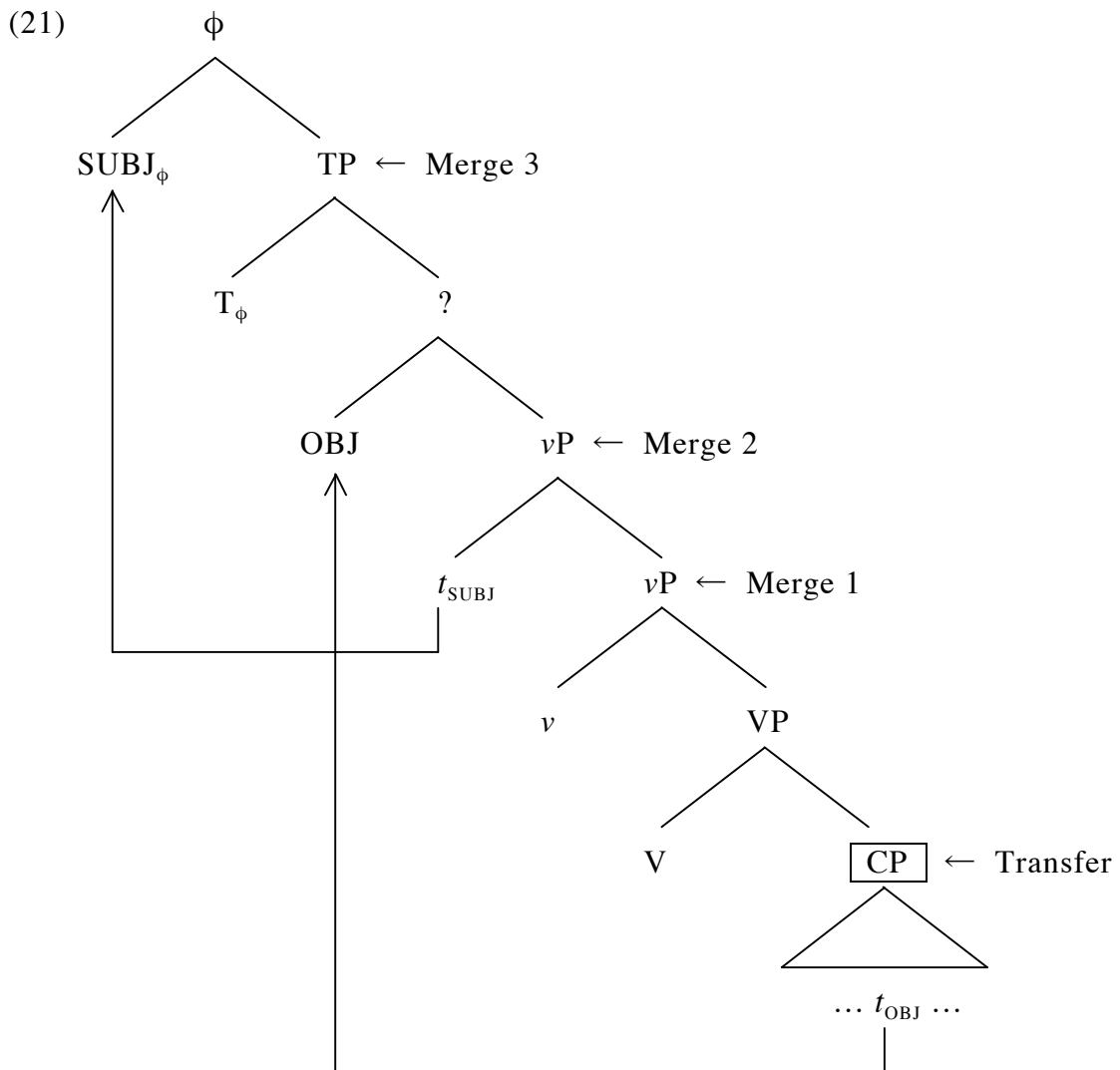

In (21), the embedded finite CP undergoes Transfer in accordance with a phase theory of Cyclic Transfer upon Merge with the matrix v head (Chomsky 2000, 2001, 2004, 2007, 2008); and SUBJ is externally merged with the v head at the

position of t_{SUBJ} to yield the predicate-internal subject construction (Merge 1); and OBJ has been moved out of the embedded clause to the outer edge of the v head (Merge 2)⁷ under the Phase-Impenetrability Condition (PIC), according to which only a phase-edge is responsible for further operations (Chomsky 2000, 2001, 2004, 2007, 2008); and SUBJ raises to SPEC-T from SPEC- v to make the subject-predicate construction (Merge 3). As mentioned above, Merge 1 and 3 yield the unlabelable $\{XP, YP\}$ structures, i.e., $\{t_{\text{SUBJ}}, vP\}$ and $\{\text{SUBJ}, \text{TP}\}$, but they are eventually labeled vP and ϕ appropriately through SUBJ-raising and ϕ -feature-agreement. Hence, the SOs created by Merge 1 and 3 are unproblematic for labeling. The problematic structure is the one given by Merge 2. Here, the form of $\{XP, YP\}$ (OBJ, vP) is created, but it won't be able to receive a label: since OBJ is stuck in the edge of the v head, a position in which neither IM nor Agree can participate, the SO remains to be invisible to LA; therefore it is ruled out at the interfaces as an unlabeled structure without interpretation:

(22) * $\{\text{OBJ}, vP\}$

Specifically, given that Agree and Transfer of uninterpretable features must happen together in terms of the principle of Full Interpretation (Chomsky 2007, 2008, Richards 2007), it follows that at the stage of the derivation where the embedded CP is transferred, relevant agreement features of OBJ have already been transferred altogether with those of the embedded v -V upon Agree. Hence, by the time when OBJ is raised to the edge of the matrix v head, it should have

⁷ Following Takita (2010), I assume that the first possible landing site for an element to be extracted from an embedded finite clause is the outer edge of the matrix v head.

no agreement features that might be prominent for LA. This makes sense given that a probe-goal relation between T and SUBJ at the position of t_{SUBJ} serves as a prerequisite for the SUBJ-raising and the subsequent LA of the relevant SOs created by Merge 1 and 3. If OBJ had a set of ϕ -features at the νP -edge position, it would trigger intervention effects for the necessary operations, and hence the required LA would not be conducted after all.⁸

Consequently, to label the $\{\text{OBJ}, \nu\text{P}\}$, OBJ must raise:

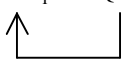
(23) a. $\text{OBJ}_i \dots \{t_i, \nu\text{P}\}$

b. $\text{LA}(\{t_i, \nu\text{P}\}) = \nu\text{P}$

(24)

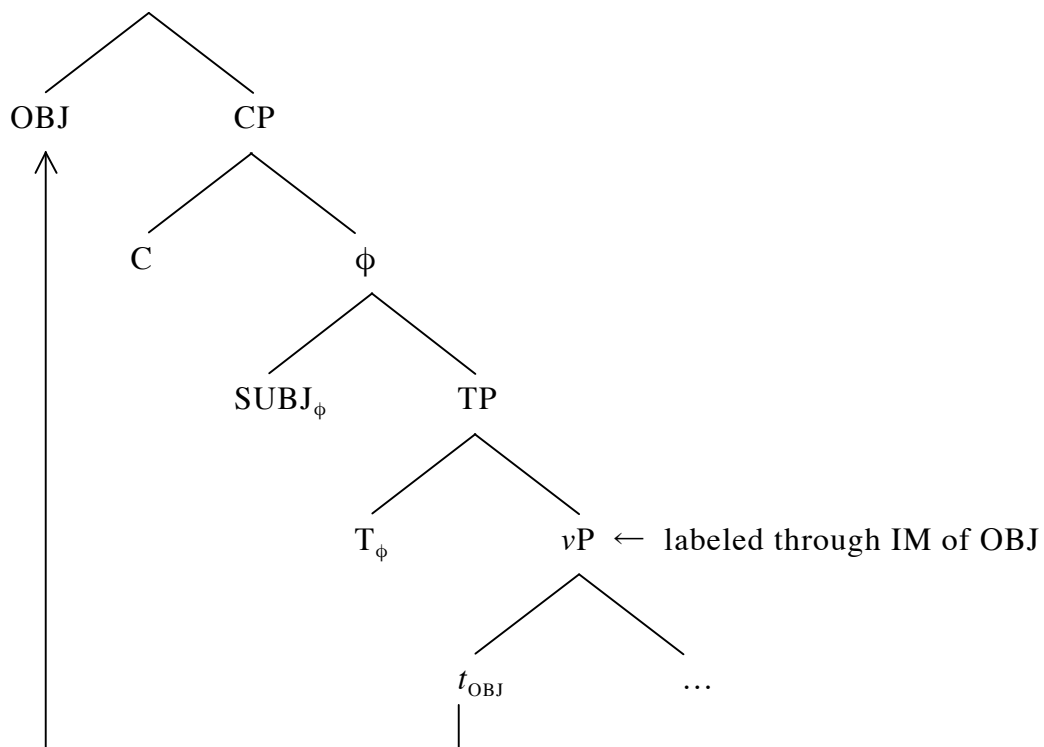

⁸ The same scenario can be applied to successive-cyclic *wh*-movement in English, as Obata and Epstein (2011) argue.

If OBJ raises like this, then the SO is labeled vP , as required. This is exactly for the grammatical example in (18b), where IM of OBJ is forced by the need to label the SO.

Here a potential problem arises: How can $\{XP, YP\}$ that is yielded at the final stage of the derivation be labeled? Put differently, how can $\{XP, YP\}$ at the edge of root CP be labeled? For example, in (24), $\{OBJ, CP\}$ is created at the edge of root CP, but it is not obvious, at present, how the whole structure should be treated under the situation where neither IM nor Agree can apply anymore.

Thus, following Goto (2012), I put forward the following hypothesis:

(25) Labels are necessary for $\{XP, YP\}$ structures at intermediate positions, but unnecessary for ones at the edge of root CP.

Given this hypothesis, it follows that an $SO = \{XP, YP\}$ may not be labeled if it is the one given at the edge of root CP, i.e., at the final stage of the derivation.⁹

¹⁰ Intuitively, given that a label is required for further computations in narrow

⁹ Naoki Fukui and Hiroki Narita (personal communication) point out that the claim that a label of the SO at the final stage of the derivation is unnecessary is somewhat misleading given that a label is required for interpretation at the interfaces. That is, they point out that if a label is required for “interpretation” (Chomsky 2012), then a label should be assigned to any SO whether it is at root or not. To avoid this confusion and maintain consistency, it may be reasonable to introduce the hypothesis (25) in terms of Chomsky’s (2007, 2008) hypothesis that a label is necessary for “further computations,” as Hiroki Narita suggests. In any case, the problem of why and for what reasons labels are required still seems to remain to be solved (Fukui and Narita forthcoming). Thus, in this paper, I would like to take a modest position by assuming that labels are necessary both for further computations in narrow syntax and for interpretation at the interfaces (see footnote 1). However, see Narita (to appear) and Narita and Fukui (2012) for prospects for a theory of label-free syntax and a very interesting alternative in terms of the notion of symmetry. Incidentally, Hiroki Narita points out that the privilege of the root from labeling may be able to account for the core property of Topicalization, a root phenomenon, which disallows multiple topics in the root clause.

¹⁰ If it were labeled, discourse-related features such as Top and Focus and so on might be assigned as most prominent features (Rizzi 1997, see also Chomsky 2008: 140). Given that

syntax (Chomsky 2007: 8; see also Chomsky 2008 and Hornstein 2009), it follows that a label of the SO at the final stage of the derivation is unnecessary, just because computation terminates there. What is more, it seems to be worth mentioning here that the traditional Phrase Structure Rules PSRs (Chomsky 1957) described root CP as follows:

(26) $S \rightarrow NP VP$

This description suggests that root CP is non-endocentric, though other phrasal constituents like VP and NP are endocentric: $VP \rightarrow V NP$; $NP \rightarrow (D) N$, etc. The non-endocentricity of root CP may look peculiar, but it naturally falls into place under the hypothesis (25): root CP is non-endocentric because labeling (or projection in X-bar theoretic terms; cf. Chomsky 1970) does not take place there. Under these considerations, therefore, the hypothesis (25) is not so implausible. It is a natural reinterpretation of the architecture of linguistic computation and the traditional description of PSRs in terms of labeling.

Here, it is important to notice that we have so far assumed that all SOs that reach the interfaces must be labeled following what Chomsky (2012) calls the general principle (cf. Section 2.1), but the situation has now been somewhat relaxed. That is, given the hypothesis (25), intermediate $\{XP, YP\}$ structures should be subject to critical scrutiny, and labeling of $\{XP, YP\}$ structures given at the final stage of the derivation may be ignored in a certain sense. Indeed, as

root CP interfaces with discourse, it might be reasonable further to conjecture that such a process is in fact implemented in terms of a discourse-bound probing, not the usual clause-bound probing, constrained by syntax-external factors. Alternatively, given that a head H is always merged to the edge of root CP to link syntax and discourse (cf. Cinque 2008), a label of $\{XP, YP\}$ in the edge may be the label of the H.

Chomsky (2012) notices, the idea that every SO must be labeled is a residue of X-bar theory and its stipulations, and may fall away under the simplest Merge-based system. Hence, while a clear understanding of when labeling is or is not required is still pending (see footnotes 1 and 9), I will here assume that labels are necessary for intermediate {XP, YP} structures, reflecting the intuitive idea that they are necessary not only for interpretation but also for further computations in narrow syntax (Chomsky 2007, 2008, Hornstein 2009).

Needless to say, attempting to consider all relevant intermediate {XP, YP} structures in terms of labeling would be way too ambitious. As a result, in the following, I will confine myself to some *prima facie* counterexamples to the proposal, leaving some obvious problems unresolved and putting them aside for future research.

3.2 Licit Intermediate {XP, YP} Structures

One apparent counterexample to the proposed analysis is {XP, YP} structures created by the so-called multiple scrambling. The relevant example is given in (27):

(27) (based on Saito (2003: 499))

Sono hon-o_i ***Hanako-ni_j*** Taroo-ga [_{CP} Ziroo-ga *t_j* *t_i* watasita to]
 that book-acc Hanako-ni Taroo-nom Ziroo-nom handed that
 omotteiru (koto)
 think fact

‘That book_i, to Hanako_j, Taroo thinks that Ziroo handed *t_i* *t_j*’

In (27), two elements *sono hon-o* ‘that book’ and *Hanako-ni* ‘to Hanako’ undergo multiple scrambling, with the former terminating at the sentence-final position while the latter at the sentence-medial position. Here, it is important to notice that scrambling of *Hanako-ni* yields an intermediate {XP, YP} structure:

(28) SO = {Hanako-ni, Taroo-ga ...}

Clearly, this SO resides in the position in which neither IM nor Agree can apply. Hence it seems that LA is not invoked and as a result the SO is not labeled. Given that an unlabelable {XP, YP} structure causes the badness of a sentence, as I have argued above, it should be expected that (27) is on a par with, at the very least, with the marginal example in (18c) with respect to the grammaticality. However, the expectation is contrary to the fact. The intermediate SO in (28) involving multiple scrambling can somehow circumvent the labeling problem, unlike the one with long-distance scrambling (cf. (20)). The question is thus: Why can {XP, YP} structures created by multiple scrambling circumvent the labeling problem?

The solution may lie in the fact that the fronted phrases by multiple scrambling form an intonation phrase, and in fact, they form a single syntactic constituent (Koizumi 2000, Takano 2002, Fukui and Sakai 2003, Ishihara 2012). Koizumi among others proposes that despite its appearance, multiple scrambling does not involve multiple occurrences of phrases in multiple positions but rather involves only one instance of long-distance movement of a remnant VP whose V head is raised to T before this VP movement takes place (see his original paper and references cited above for relevant arguments for this approach to multiple

scrambling). Under this approach, therefore, (27) can be analyzed as having the following derivation (DP = *sono hon-o* ‘that book’; PP = *Hanako-ni* ‘to Hanako’; SUBJ = *Taroo-ga*):

(29)

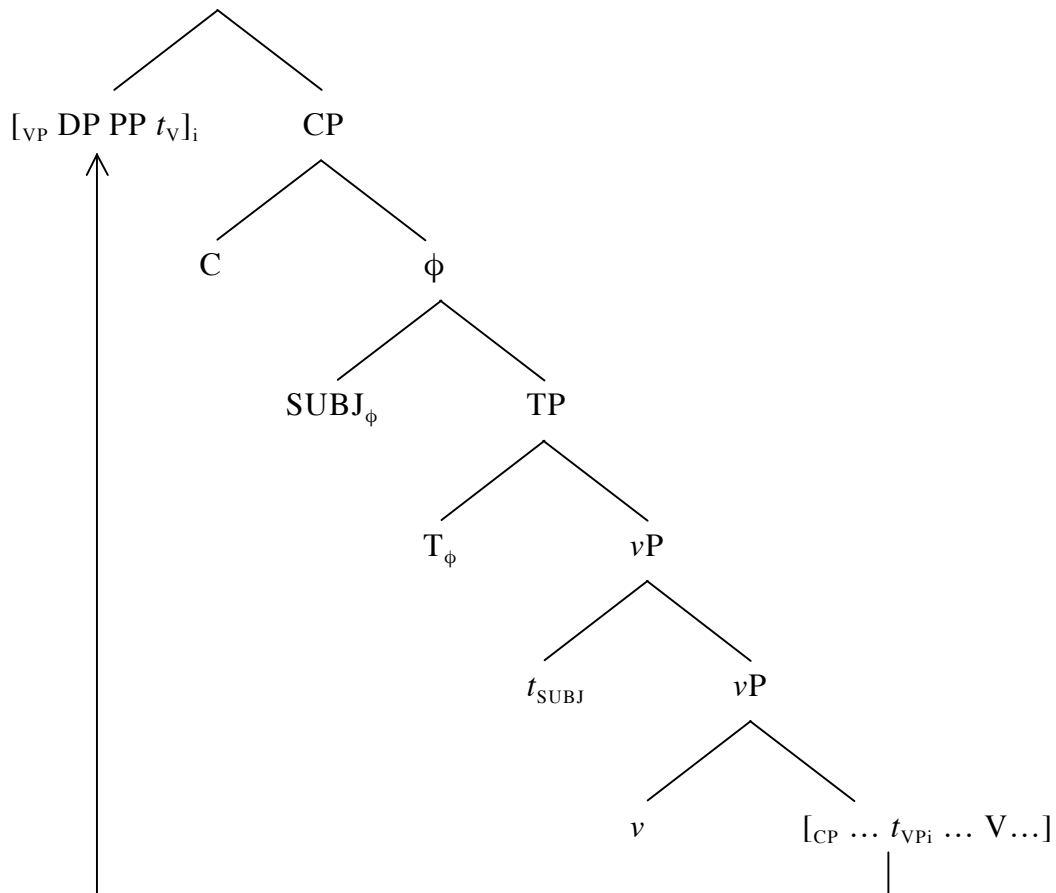

In (29), DP and PP do not undergo multiple scrambling separately; rather they undergo long-distance scrambling as a single syntactic constituent, i.e., VP in this case (I omit possible landing sites of long-distance scrambling of VP).¹¹ Here, it is quite significant to notice that PP is at the edge of root CP together with DP. This consideration seems to pave the way for solving the problem of

¹¹ Below I will discuss how the label of the double object {DP, PP} is determined.

why the intermediate {XP, YP} structure in (28), i.e., {Hanako-ni, Taroo-ga ...} (PP, TP), can circumvent the labeling problem: since PP is now at the edge of root CP, the intermediate SO in (28) is privileged from labeling under the hypothesis (25), for the same reasons as the grammatical example in (18b). Thus, given the single syntactic constituent movement approach to multiple scrambling, the potential problem of labeling with multiple scrambling can be solved by making the best use of the hypothesis (25).¹²

So far, we have limited our discussion to cases involving long-distance scrambling, but how can we deal with {XP, YP} structures involving clause-internal scrambling? The relevant example is given in (30):

- (30) a. Taroo-ga Hanako-ni sono hon-o watasita
 Taroo-nom Hanako-to that book-acc handed
 ‘Taroo handed that book to Hanako.’
- b. Taroo-ga *sono hon-o_i* Hanako-ni *t_i* watasita
 Taroo-nom that book-acc Hanako-to handed
 ‘Taroo, that book, handed to Hanako.’

It has been customary to assume that the indirect object (IO) precedes the direct object (DO) in their base word order in Japanese (cf. Takano 1998).¹³ Thus,

¹² I thank Jun Abe and Hiroki Narita (personal communication) for pointing out this line of reasoning under the hypothesis (25). For an alternative view, see Goto (2012), where he argues, following Giorgi (2012), that intonation can function as a prominent feature, properly characterizable as devices to label an SO in the course of the derivation.

¹³ In fact, there has been some controversy on the basic word order of double objects. Miyagawa (1997) among others argues that the IO-DO order and the DO-IO order are both base-generable. If this is the case, (30b) will be derived without involving clause-internal scrambling, and the potential problem of labeling discussed below will be dismissed. In what follows, however, I dare to address the question how labeling is involved in the basic

(30a) represents the basic word order of the double-object construction, and (30b) is derived from (30a) by clause-internal scrambling of *sono hon-o* to the sentence-medial position between *Taroo-ga* and *Hanako-ni*:

(31) SO = {sono hon-o, Hanako-ni ...}

Why can this intermediate SO circumvent the labeling problem?

We can solve this question by adopting Chomsky's (2008, 2012) analyses of DOs and IOs. Chomsky (2008) argues that DOs raise to SPEC-V through ϕ -feature-agreement with V, analogously to SUBJ-raising to SPEC-T (cf. (21)), and Chomsky (2012) suggests that IOs can be introduced to the structure by Pair-Merge.¹⁴ Assuming these, then, we can represent the relevant structure of (30b) as follows (DP = *sono hon-o* 'that book'; PP = *Hanako-ni* 'to Hanako'):

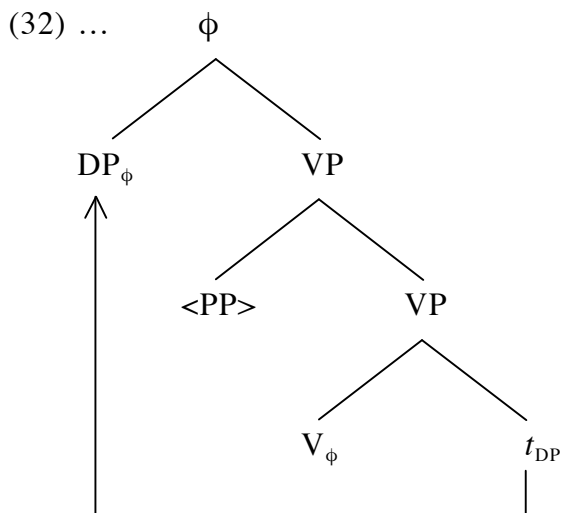

{XP, YP} structure of the double object construction in Japanese (see footnote 11).

¹⁴ Pair-Merge differs from simple Merge in that it forms a pair, not a set: Pair-Merge(X, Y) = <X, Y>. Pair-Merge is assumed to induce the asymmetry characteristic of adjuncts, and can be applied indefinitely (Chomsky 2004, 2008, 2012).

First, in (32), V and DP merge. Since V is a single designated element here, LA can unambiguously select it as the label of the SO. Then PP is pair-merged to VP. Importantly, Pair-Merged SOs, not being necessary to the derivation, do not necessarily have to undergo labeling (cf. Chomsky 2004, 2012, Hornstein 2009), so therefore, the resulting SO can inherit the label of VP when PP is introduced. Lastly, DP and VP share prominent features, namely ϕ -features, so that LA can take those to be the label of the SO, in the same way as the TP domain (cf. (21)):

$$(33) \text{LA}(\{\text{DP}_\phi, \text{VP}_\phi\}) = \phi$$

Thus, the seemingly problematic SO in (31) appropriately receives the label of ϕ , and the potential problem of labeling with clause-internal scrambling can also be solved particularly considering Pair-Merge and Agree at the relevant domain. From this point of view, a label of VP in (29) will be ϕ .

Finally, let us consider why examples like the following do not raise the labeling problem:

- (34) Taroo-wa [_{CP} *sono hon-o*_i Hanako-ga *t*_i mottei-ru to] it-ta.
 Taroo-top that book-acc Hanako-nom have-pres that say-past
 ‘(lit.) Taroo said [that that book, Hanako has *t*_i]

Here, *sono hon-o* ‘that book’ undergoes scrambling to the edge of the embedded clause. As indicated, we know that the entire clause should be labeled CP. But, how is it possible? Consider the following schematic derivation of the embedded clause (OBJ = *sono hon-o* ‘that book’; SUBJ = *Hanako-ga*):

(35) ... ?

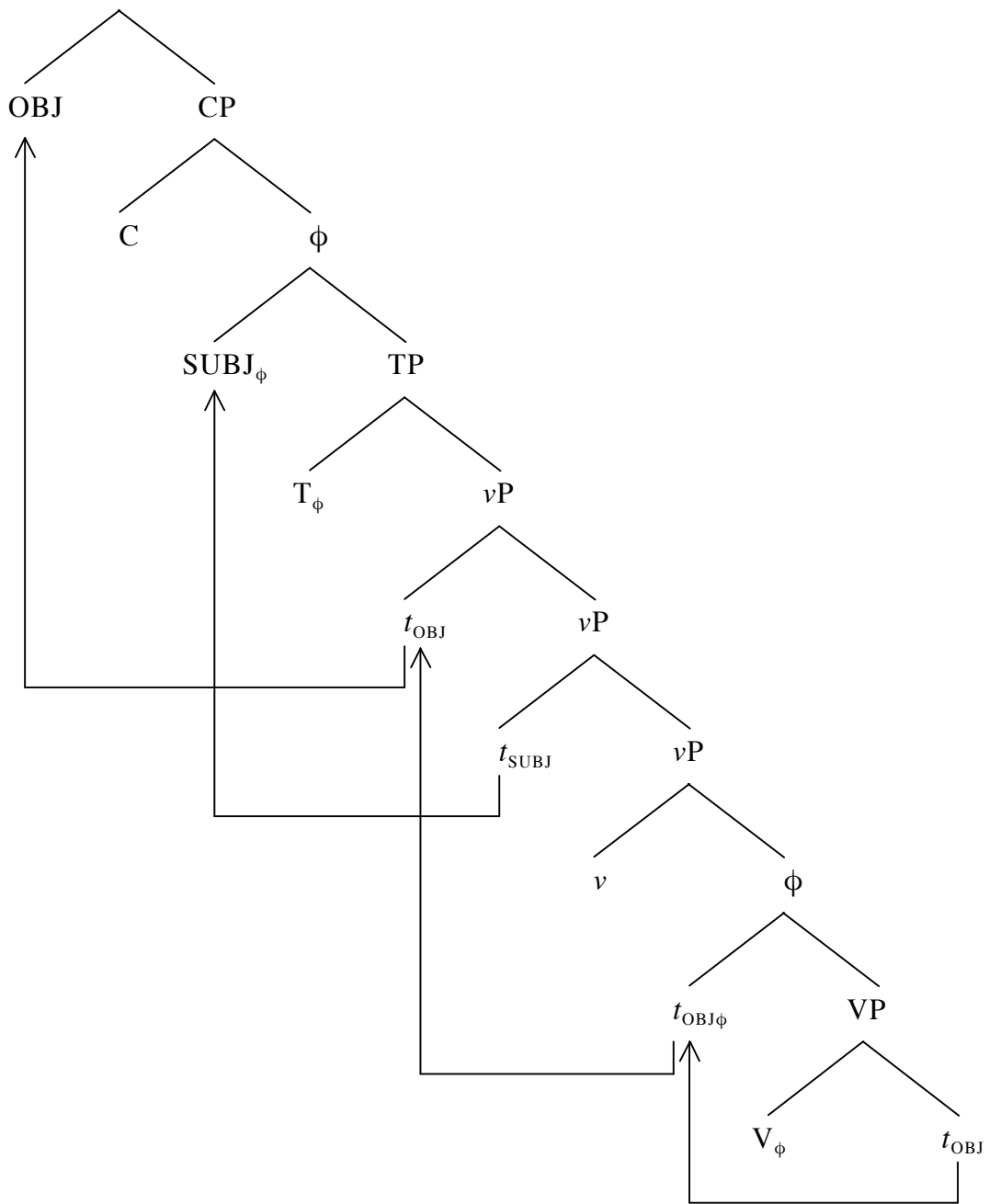

In (35), the derivation proceeds step by step, under the PIC, and SUBJ and OBJ get settled at the relevant surface positions through appropriate Agree and IM (see (21) for the derivation of SUBJ and (24) and (32) for the derivation of OBJ). As usual, the labels of the intermediate SOs in the VP and TP domains are

properly determined by the systematically available IM and ϕ -feature-agreement. The problematic SO is clearly the one given at the edge of the embedded clause:

(36) $SO = \{OBJ, CP\}$

Since this is the form of $\{XP, YP\}$ that cannot involve IM, Agree, and the privilege of the root, namely, hypothesis (25), the obvious question is: Why can $\{XP, YP\}$ structures created at the edge of the embedded clause circumvent the labeling problem?

Transfer seems to have the key to solving the problem. In a phase theory of Cyclic Transfer, it has been assumed that the complement of C, i.e., TP labeled ϕ , undergoes Transfer upon relevant ϕ -feature-inheritance/agreement in accordance with the principle of Full Interpretation (Chomsky 2007, 2008, Richards 2007). Significantly, as Narita (to appear) extensively argues, if Transfer can reduce at least one of XPs to a simplex SO, then it is expected that the structure of (35) will be as follows after TP/ ϕ -Transfer takes place:

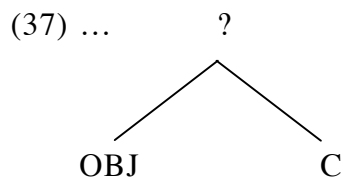

Here, by transferring the complement of the phase head, it follows, in effect, that only C and OBJ at the edge remain in the derivational space:

(38) $SO = \{OBJ, C\}$

Given this SO, the solution is obvious: since this is an instance of $\{H, XP\}$, LA can unambiguously select C as the label of the SO:

$$(39) \text{LA}(\{\text{OBJ}, C\}) = C$$

In this manner, we can solve the potential problem of labeling in the embedded clause too, by considering the efficient and optimal way of Transfer.^{15, 16}

In summary, the seemingly problematic intermediate $\{XP, YP\}$ structures observed in multiple scrambling, clause-internal scrambling, and the edge of the embedded clause can be accommodated to the proposed analysis of $\{XP, YP\}$ structures, particularly in collaboration with the following independently motivated assumptions: Koizumi's (2000) single syntactic movement approach to multiple scrambling, Chomsky's (2008, 2012) analysis of double objects, and Narita's (to appear) analysis of Transfer. Based on these assumptions, I illustrated that the relevant structures can avoid the potential labeling problems. If the suggested approaches prove viable, it would be cases where labeling forces an appropriate analysis of relevant $\{XP, YP\}$ structures in Japanese.

¹⁵ VP/ ϕ -Transfer might have the same effect on labeling ν P. Since many loose ends such as ν -to-V-raising remain, I will not commit myself further on this point.

¹⁶ Note that this analysis of labeling of the embedded clause does not nullify the hypothesis (25) and the suggested analysis of the ban on long-distance scrambling to a sentence-medial position in the root clause. With respect to the edge of the root clause, Transfer applies in full (Chomsky 2004, Goto 2011, Narita to appear, Obata 2010), so that Transfer cannot play a role in labeling $\{XP, YP\}$ structures at the edge of the root clause. Thus, the Transfer-based analysis of $\{XP, YP\}$ structures at the edge of the embedded clause keeps the hypothesis (25) and the suggested analysis intact.

4 Conclusion

In this paper, I adopted and elaborated Chomsky's (2012) Merge-based system with labeling algorithm (LA) and proposed a novel explanation of the ban on long-distance scrambling to a sentence-medial position in Japanese in terms of LA, with the consequence that the Merge-over-Move Principle (MOM) (Chomsky 1995, 2000) is entirely eliminated in favor of unconstrained Merge. Specifically, I put forward the hypothesis that a label is necessary for {XP, YP} structures at intermediate positions, but unnecessary for ones at the edge of root CP, reflecting the intuitive idea that it is necessary not only for interpretation at the interfaces (Chomsky 2012) but also for further computations in narrow syntax (Chomsky 2007, 2008, Hornstein 2009). I argued that the hypothesis straightforwardly captures the traditional intuition of Phrase Structure Rules (PSRs) that root CP is non-endocentric (Chomsky 1957). As apparent counterexamples to the hypothesis, I considered some legitimate intermediate {XP, YP} structures observed in multiple scrambling, clause-internal scrambling, and embedded clauses. Based on the nature of the independently motivated notions such as single syntactic constituent movement (Koizumi 2000), Pair-Merge (Chomsky 2004, 2008, 2012), and Transfer (Narita to appear), I illustrated that the relevant {XP, YP} structures can avoid the potential labeling problem. Though there still remain several important points left open; in particular, the necessity of labeling, I believe that this paper brought new insight into {XP, YP} structures in Japanese, and provided conceptual/theoretical and empirical support for Chomsky's (2012) Merge-based system with labeling.

References

- Abe, Jun. (2009). How to probe expletives. Ms., Tohoku Gakuin University.
- Chomsky, Noam. (1957). *Syntactic Structures*. The Hague: Mouton.
- Chomsky, Noam. (1970). Remarks on nominalization. In Roderick A. Jacobs and Peter S. Rosenbaum (eds.), *Readings in English Transformational Grammar*, 184-221. Waltham, MA: Ginn.
- Chomsky, Noam. (1981). *Lectures on Government and Binding*. Dordrecht: Foris.
- Chomsky, Noam. (1995). *The Minimalist Program*. Cambridge, MA: MIT Press.
- Chomsky, Noam. (2000). Minimalist inquiries: the framework. In Roger Martin, David Michaels, and Juan Uriagereka (eds.), *Step by Step: Essays on Minimalist Syntax in Honor of Howard Lasnik*, 89-155. Cambridge, MA: MIT Press.
- Chomsky, Noam. (2001). Derivation by phase. In Michael Kenstowicz (ed.), *Ken Hale: A Life in Language*, 1-52. Cambridge, MA: MIT Press.
- Chomsky, Noam. (2004). Beyond explanatory adequacy. In Adriana Belletti (ed.), *Structures and Beyond: The Cartography of Syntactic Structures Volume 3*, 104-131. New York: Oxford University Press.
- Chomsky, Noam. (2005). Three factors in the language design. *Linguistic Inquiry* 36: 1-22.
- Chomsky, Noam. (2007). Approaching UG from below. In U. Sauerland and H.-M. Gärtner (eds.), *Interfaces + Recursion = Language? Chomsky's Minimalism and the View from Semantics*, 1-29. Berlin and New York: Mouton de Gruyter.
- Chomsky, Noam. (2008). On phases. In Robert Freidin, Carlos Otero, and Maria Luisa Zubizarreta (ed.), *Foundational Issues in Linguistic Theory*, 133-166.

- Cambridge, MA: MIT Press.
- Chomsky, Noam. (2012). Problems of projection. Ms., MIT (to appear in a special issue of *Lingua*, ed. Luigi Rizzi).
- Cinque, Guglielmo. (2008). Two types of non-restrictive relatives. In O. Bonami & P. Cabredo Hofherr (eds.), *Empirical Issues in Syntax and Semantics 7*, 99-137. Paris: CNRS.
- Epstein, Samuel. D., Hisatsugu Kitahara and T. Daniel Seely. (in prep.). Labeling by minimal search – Implications for successive cyclic A-movement and for the conception of the postulate “phase” – Ms., University of Michigan, Keio University, and Eastern Michigan University.
- Fukui, Naoki, and Hiromu Sakai. (2003). The visibility guideline for functional categories: verb raising in Japanese and related issues. *Lingua* 113: 321-375.
- Fukui, Naoki, and Hiroki Narita. (forthcoming). Merge, labeling, and projection. In A. Carnie et al. (eds.), *Routledge Handbook of Syntax*. London: Routledge.
- Giorgi, Alessandra. (2012). Prosodic signals as syntactic formatives in the left periphery. Ms., Ca' Foscari University, Venice.
- Goto, Nobu. (2011). Feature-inheritance: Its effects on Agree, Move, and Delete. Doctoral dissertation. Tohoku Gakuin University.
- Goto, Nobu. (2012). Hego to raberuzuke wo meguru oboegaki [Notes on Merge and Label]. Paper presented at the 145th annual meeting of the Japanese linguistic society of Japan, Kyusyu University, Japan, November 24, 2012.
- Hornstein, Norbert. (2009). *A Theory of Syntax: Minimal Operations and Universal grammar*. Cambridge: Cambridge University Press.
- Ishihara, Shinichiro. (2012). The clause-mate condition: a prosodic account. Paper presented at the Formal Approaches to Japanese Linguistics 6 (FAJL

- 6), Humboldt University, September 27, 2012.
- Koizumi, Masatoshi. (2000). String-vacuous overt verb movement. *Journal of East Asian Linguistics* 9: 227-285.
- Moro, Andrea. (2000). *Dynamic Antisymmetry*. Cambridge, MA: MIT Press.
- Miyagawa, Shigeru. (1997). Against optional scrambling. *Linguistic Inquiry* 28: 1-25.
- Narita, Hiroki. (2012). Remarks on the nature of headedness and compositionality in bare phrase structure. In *Proceedings of Sophia University Linguistic Society* 26, 81-126.
- Narita, Hiroki. (to appear). *Endocentric Structuring of Projection-Free Syntax: Phasing in Full Interpretation*. Amsterdam: John Benjamins.
- Narita, Hiroki and Naoki Fukui. (2012). Merge and (A)symmetry. Ms., Waseda Institute for Advanced Study and Sophia University.
- Obata, Miki. (2010). Root, successive-cyclic and feature-splitting Internal Merge: Implications for Feature-Inheritance and Transfer, Doctoral dissertation. University of Michigan.
- Obata, Miki and Samuel David Epstein. (2011). Feature-splitting internal Merge: improper movement, intervention and the A/A'-distinction. *Syntax* 14(2): 122-147.
- Ott, Dennis. (2012). *Local Instability*. Berlin/New York: Walter De Gruyter.
- Richards, Marc D. (2007). On feature inheritance: an argument from the phase impenetrability condition. *Linguistic Inquiry* 38: 563-572.
- Rizzi, Luigi. (1997). The fine structure of the left periphery. In L. Elaegean (ed.), *Elements of Grammar: Handbook of Generative Syntax*, 281-337. Dordrecht: Kluwer.

- Rizzi, Luigi. (2006). On the form of chains: criterial positions and ECP effect. In Lisa Cheng and Norbert Corver (eds.), *Wh-Movement: Moving on*, 97-133. Cambridge, MA: MIT Press.
- Rizzi, Luigi. (2012). Cartography, criteria, and labeling. Ms., University of Siena, University of Geneva.
- Saito, Mamoru. (1985). Some asymmetries in Japanese and their theoretical implications. Doctoral dissertation. MIT.
- Saito, Mamoru. (2003). A derivational approach to the interpretation of scrambling chains. *Lingua* 113: 481-518.
- Sato, Mai. (2008). Where is there?: an approach to the expletive construction, M.A. dissertation. Tohoku Gakuin University.
- Sorida, Masanobu. (2012). Unweaving chains. Doctoral dissertation. Sophia University.
- Takano, Yuji. (1998). Object shift and scrambling. *Natural Language and Linguistic Theory* 16: 817-889.
- Takano, Yuji. (2002). Surprising constituents. *Journal of East Asian Linguistics* 11: 243-301.
- Takita, Kensuke. (2010). Cyclic linearization and constraints on movement and ellipsis. Doctoral dissertation. Nanzan University.
- Uriagereka, Juan. (2008). *Syntactic Anchors: On Semantic Structuring*. Cambridge: Cambridge University Press.